

A tradition of innovation since 1966



model TC-12

[tree chipper]



DURATECH....Clearing the way for a better tomorrow.

DuraTech has harnessed the grinding technology of its massive tub and horizontal grinders and implemented it in the new TC-12 Tree Chipper. With a 122 hp (91 kw) CAT C4.4 diesel engine and PT-Tech clutch, the powerful TC-12 can grind trees and limbs up to 12 inches in diameter. The TC-12 features a spring loaded feed wheel with adjustable down pressure, an optional height sensor that automatically adjusts the feed roller to material size, an optional hydraulic gathering winch, and innovative hopper safety bars with easy and instant feed wheel shut off. Available with a pintle or ball hitch, this heavy duty chipper is compact enough to easily tow anywhere.

FEATURE



PT Tech HPTO 8 microprocessors-controlled clutch with 4-groove belt system. The HPTO Clutch provides easy startups and provides torque overload protection for the disc, engine and driveline.

FEATURE



The chipping disc is 42" in diameter and 2" thick. There are four 7-3/4" knives in two locations on the disc. Four kickers help to discharge material from disc area. A convenient service lock pin holds the disc solid while servicing the knives on the disc.

FEATURE

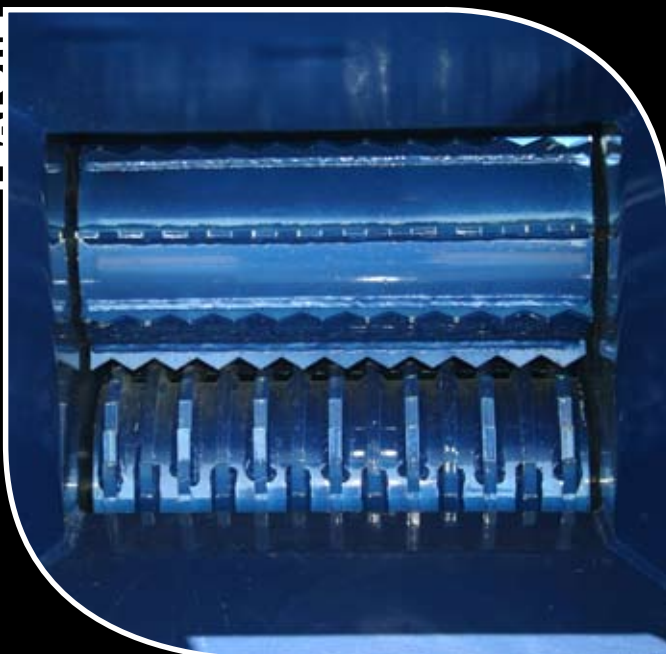

The feed roller is equipped with adjustable, dual spring-loaded down-pressure, which continually applies optimum down-force on material flow. It is also equipped with hydraulics to lift feed roller if required.

Control panels are accessible on both sides of the hopper. Each control panel contains an emergency stop button. An emergency bumper bar is also located on either side of the hopper for instant shut-off of the feed wheel.

The optional feed height sensor is located at the top of the hopper. After sensing the height of the log, the feed wheel will automatically adjust the feed wheel to allow larger logs to enter more easily. The optional gathering winch hydraulically helps pull larger logs up to the hopper. Free wheeling discharge allows for easier unrolling of winch.

The TC-12 is designed with easy access to the anvil. The anvils are made of $\frac{1}{2}$ " AR 400 steel plate and each has four cutting edges.

FEATURE



FEATURE



FEATURE



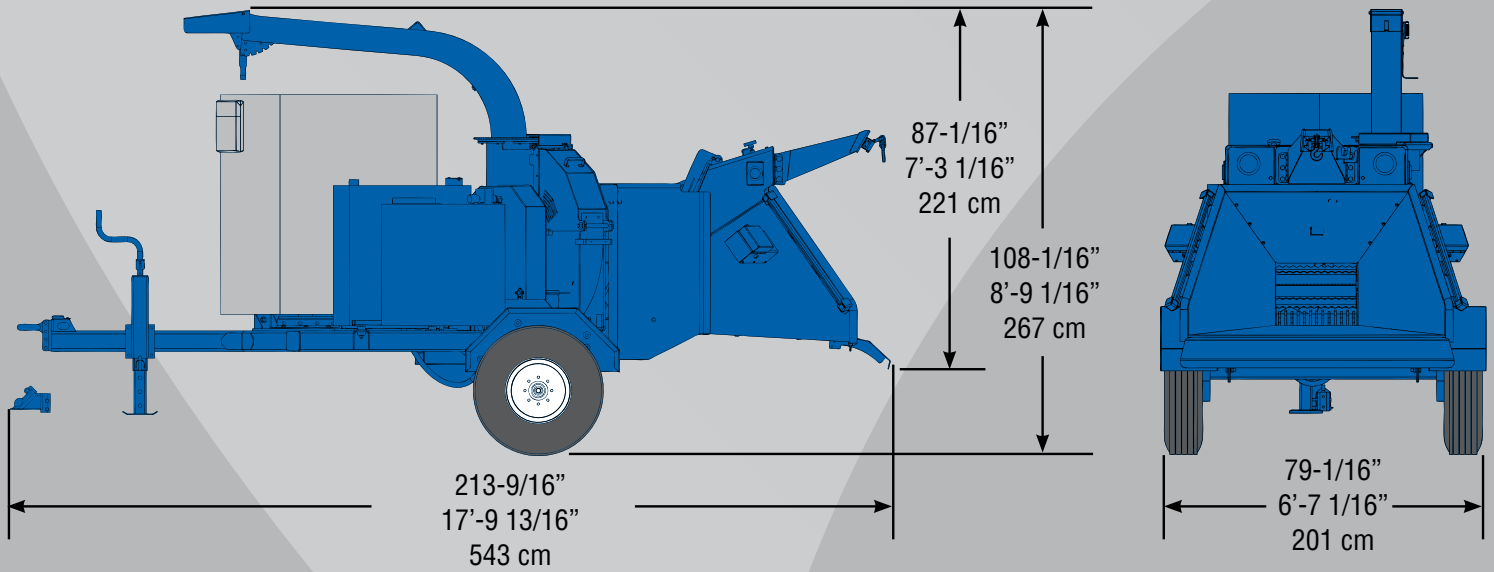

SPECIFICATIONS

model TC-12
[tree chipper]

Engine	CAT C4.4 122 HP (91 kW)	Throat Opening	12" x 20" (30cm x 51cm)
Gross Weight	7,640 lbs. (3,465.5 kg)	Disc Size	42" (107cm) dia. x 2" (5cm)
Transport Width	6' 7-1/16" (201cm)	Disc Shaft Size	3-15/16" (10cm) dia.
Transport Length	17' 9-13/16" (543cm)	Feed System	Hydraulic 2 Drum
Transport Height	8' 9-1/16" (267cm)	Number of Knives	4, 2 slots
Hitch	Pintle or 2-5/16" Ball	Size of Knives	4-1/2" (11.5cm) x 7-3/4" (19.5cm)
Tongue Weight	740 lbs.(335.7kg)		3-bolt
Jack	7,000lbs (3,175.2kg)	Feed Wheel	Adjustable Hydraulic and Spring Loaded Down Pressure System
Axle	7,000lbs (3,175.2kg) Torflex	Discharge System	360°, Hydraulic Rotation w/ Adjustable Chip Spout
Suspension	Torsional	Safety Features	Breakaway Brake Switch, 2 E-Stop Switches, 2 Infeed Hopper Light Bars, and Disc Hood Closed Proximity Switch
Brakes	Electric	Frame Size	3" (7.6cm) x 5" (12.7cm) x 1/4"(0.64 cm)
Tires	235/85R 16E	Feed Height Sensor	Optional
Fuel Capacity	40 gal (152 L)	Gathering Winch	Optional
Hydraulic Oil Capacity	25 gal (95 L)		
Electrical	24V		
Lights	Clearance and Directional		
Transmission	PT Tech HPTO 8		
Chipping Capacity	12" (30.5cm)		
Infeed Hopper Opening	40" x 62" (102cm x 157cm)		

Illustrations, specifications, and descriptions contained herein were accurate at the time of publication, but are subject to change without notice. Illustrations may include optional equipment and accessories and may not include all standard equipment.

...Clearing the way for a better tomorrow.

3780 Hwy 281 SE, Jamestown, ND 58401
Phone: 1-800-243-4601
duratechindustries.net