



Tromax 7216

Trommel Screening System

Operating Instructions and Parts Reference







Foreword

All personnel must read and understand before operating unit

DuraTech Industries International Inc. (DuraTech) has made every effort to assure that this manual completely and accurately describes the operation and maintenance of the Tromax 7216 trommel screen as of the date of publication. DuraTech reserves the right to make updates to the machine from time to time. Even in the event of such updates, you should still find this manual to be appropriate for the safe operation and maintenance of your unit.

This manual, as well as materials provided by component suppliers to DuraTech Industries are all considered to be part of the information package. Every operator is required to read and understand these manuals, and they should be located within easy access for periodic review.

Appropriate use of the unit

The DuraTech Tromax 7216 trommel screen incorporates a proprietary design allowing the feed of materials of a wide variety. The trommel screen unit was designed for sizing and separating most organic material, including compost, wood waste, ground-up construction and demolition debris, many types of soils, and salt. However, it is NOT designed to screen aggregates such as rock and gravel.

Operator protection

As with all machinery, care needs to be taken in order to insure the safety of the operator and those in the surrounding area.



WARNING: Operators of the trommel screen are required to wear head, eye, and ear protection. No loose clothing is allowed.



Contents

Part 1: Operating Instructions	1
Introduction	2
Purpose	2
Section 1: Safety	4
1.1 Safety-alert symbols	4
1.2 Operator - personal equipment	6
1.3 Machine safety labels	7
1.4 Shielding	10
1.5 Trommel screen safety review	10
1.6 Fire safety	10
1.7 Important safety reminders	11
1.8 Towing	11
Section 2: Dealer Preparation	12
2.1 Brushes	12
2.2 Hopper extension	12
2.3 Adjustable feed control plates	12
2.4 Side gathering conveyor	13
2.5 Predelivery inspection	13
2.6 Engine operation check	14
2.7 Trommel screen operation check	14
Section 3: Operation	15
3.1 Description of the Tromax 7216 trommel screen	16
3.2 Description of the Tromax 7216's major components	16
3.2.1 Stripper blades	16
3.2.2 Stripper sheets	17
3.2.3 Screens	17
3.2.3a What can and can't I screen?	17
3.2.3b Screen sizes	17
3.2.4 Feed augers	18
3.2.5 Apron	18
3.2.6 Gear box and chain drive system	18
3.2.7 Brushes	18
3.2.8 Operator controls	19



TABLE OF CONTENTS

3.3 Operation	20
3.3.1 Daily preoperation inspection	20
3.3.2 Hitching to a tow vehicle	21
3.3.3 Disconnecting from a tow vehicle	22
3.3.4 Hopper loading requirements	23
3.3.5 Operation and care of a new engine	23
3.3.6 Engine starting	23
3.3.7 If the engine fails to start	24
3.3.8 Throttle operation	24
3.3.9 Automatic engine shutdown system	25
3.3.10 Starting the trommel screen	25
3.3.11 Setting barrel speed	26
3.3.12 Evaluating sized material	26
3.3.13 Setting trommel screen pitch	26
3.3.14 Replacing the screen	26
3.3.15 Unplugging and restarting the trommel screen	27
3.3.16 Normal shutdown	27
3.3.17 Emergency shutdown	27
Section 4: Engine Maintenance	29
4.1 Diesel fuel requirements	29
4.2 Engine lubrication requirements	30
4.3 Engine coolant requirements	30
4.4 Fan belt tension	30
4.5 Air cleaner	31
4.6 Operation and care of a new engine	31
4.7 If the engine fails to start	31
5.2 Bearing lubrication	32
Section 5: General Maintenance	32
5.1 Checking battery condition	32
5.3 Auger maintenance	33
5.4 Hydraulic system	34
5.5 Axles, wheels and tires	35
5.6 General appearance	35
Appendix A: Warranty	36
Appendix B: Specifications	37
Appendix C: Delivery Notification Form	39
Appendix D: User Training Verification Form	40
Appendix E: Operator Training Form	41



TABLE OF CONTENTS

Part 2: Parts Reference	43
6800208 Base Unit	45
6800118 Hopper Extension Option	47
6800245 Adjustable Feed Control Plates	47
6800212 Brush Assembly	49
6800235 Barrel Assembly	51
6800236 Paddle Option	51
6800237 Drive Assembly	53
6800209 Electric Highway Axle	55
6800122 Slow-Speed Axle Option	57
6800123 Pintle Hitch	59
6800124 Gooseneck Hitch Option	61
6800125 Fifth Wheel Hitch Option	63
6800210 Side Apron	65
6800202 Side Conveyor Assembly	67
6800203 Side Conveyor Seal Assembly	69
6800116 Rear Drop Leg	71
Rear Drop Leg Control, O-Ring	73
Rear Drop Leg Control, Pipe Thread	73
6800117 Front Drop Leg	75
Front Drop Leg Control, O-Ring	77
Front Drop Leg Control, Pipe Thread	77
6800238 Hydraulic Assembly	79
6800246 Fuel Assembly	81
Electrical Schematic	82
Electrical Schematic	83
6500312 Decal Kit 7216	87
3100199 Planetary Gearbox	89
Tromax 7216 Documentation Comment Form	91



Tromax 7216

Trommel Screening System

Manual 1:

Operating Instructions



Introduction

Your model TORMAX 7216 is designed to grind industrial waste and other materials, including wood waste, construction and demolition debris, asphalt, bricks, concrete blocks, tree branches and trunks, compostables and mulch. It is **NOT** designed to grind steel.

Purpose

The TROMAX 7216 was designed for sizing and separating most organic material, including compost, wood waste, ground-up construction and demolition debris, many types of soils, and salt. However, it is **NOT** designed to screen aggregates such as rock and gravel.



SPECIAL NOTE: When reference is made as to front, rear, left hand, or right hand of this machine, the reference is always made from standing at the rear end of the machine and looking toward the hitch. Always use serial number and model number when referring to parts or problems. Please obtain your serial number and write it below for your future reference.

MODEL: TORMAX 7216

SERIAL NO. _____

How to use this manual

- **Part 1: Operating Instructions** explains how to set up, use and maintain the Tromax 7216 trommel screen unit.
- **Part 2: Parts Reference** contains diagrams of each assembly, with the number of each part identified. A key on the facing page contains a description of the part and the quantity used.

Dealer responsibilities

- Thoroughly review Section 2, “Dealer Preparation,” and perform the tasks outlined. Also perform a daily preoperation inspection as described in Section 3, “Operation.”
- Upon delivery of the unit to the customer, it is your responsibility to conduct a training session in the safe operation of the unit for the primary operator(s). You must also conduct a “walk-around” inspection of all safety instructional decals on the machine itself. Decals are illustrated in **Part 2: Parts Reference**.
- When you are satisfied that the primary operators have read the operating instructions, and understand all information concerning the safe operation of the unit, sign and return the User Training Verification Form found in Appendix D. Note that this form requires both your signature and the signatures of up to four primary operators.
- Complete and return the Delivery Notification Form found in Appendix C. Receipt of this form is required to activate the warranty. Appendix A provides details of the warranty.



Operator responsibilities

- Review Section 2, “Dealer Preparation,” to verify that the machine has been prepared for use.
- Note the important safety information in the Foreword and in Section 1, “Safety.”
- Thoroughly review sections 1 and 3, which explain normal operation of the machine, and sections 4 and 5, which explain maintenance requirements. These sections will function as your textbook during the dealer-conducted training course that is required before you can use the unit.
- When all primary operators have read the operating instructions, and understand all information concerning the safe operation of the unit, you will be required to sign the User Training Verification Form found in Appendix D. Note that this form requires both the dealer signature and the signatures of up to four primary operators. The dealer is responsible for returning the signed form to DuraTech Industries.
- Manuals for the Isuzu engine and certain other third-party components are provided separately. You should also be familiar with their contents.
- Keep copies of all manuals in a readily-accessible location for future reference.



Section 1: Safety

Thank you for taking the time to read the operation and maintenance manual for the DuraTech TORMAX 7216. Because your safety and that of others is of the utmost importance, you should familiarize yourself with this entire manual before operating this unit.

The TROMAX 7216 incorporates a number of third party products. For example, the engine, and hydraulic pumps are third party products. More information about the operation and care of these products can be found in each product's respective manual(s). Before operating this unit, you should familiarize yourself with these manuals as well.

Safety is an ongoing job experience, and DuraTech has made every effort to make sure that the TORMAX 7216 provides operator comfort and security. DuraTech encourages you to bring to our attention as quickly as possible any suggestions you may have concerning the safety of the equipment. DuraTech is dedicated to enhancing the safety of the TORMAX 7216.

This unit is supplied with an operation and maintenance manual and this manual should be kept with the unit for periodic review by operational personnel.

Operators of the TORMAX 7216 are required to wear head, eye, and ear protection as well as clothing appropriate for the application. Individuals with loose clothing, unrestrained long hair, jewelry, or other accessories which may hang loosely away from the body should not be allowed on or near the machine.



WARNING: FAILURE TO COMPLY WITH SAFETY INSTRUCTIONS THAT FOLLOW WITHIN THIS MANUAL COULD RESULT IN SEVERE PERSONAL INJURY OR DEATH. BEFORE ATTEMPTING TO OPERATE THIS MACHINE, CAREFULLY READ ALL INSTRUCTIONS CONTAINED WITHIN THIS MANUAL.

THIS MACHINE IS NOT TO BE USED FOR ANY PURPOSE OTHER THAN THOSE EXPLAINED IN THE OPERATOR'S MANUAL, ADVERTISING LITERATURE OR OTHER DURATECH WRITTEN MATERIAL PERTAINING TO THE TORMAX 7216.

1.1 Safety-alert symbols

Decals are illustrated in **Manual 2: Parts Reference**.

The safety decals located on your machine contain important and useful information that will help you operate your equipment safely.

To assure that all decals remain in place and in good condition, follow the instructions below:

- Keep decals clean. Use soap and water - not mineral spirits, adhesive cleaners and other similar cleaners that will damage the decal.
- Replace all damaged or missing decals. When attaching decals, surface temperature of the machine must be at least 40° F (5° C). The surface must be also be clean and dry.
- When replacing a machine component to which a decal is attached, be sure to also replace the decal.
- Replacement decals can be purchased from your DuraTech dealer.



DuraTech uses industry accepted ANSI standards in labeling its products for safety and operational characteristics.



Safety-Alert Symbol

Read and recognize safety information. Be alert to the potential for personal injury when you see this safety-alert symbol.

DANGER: Indicates an imminently hazardous situation that, if not avoided, will result in death or serious injury. This signal word is to be limited to the most extreme situations, typically for machine components that, for functional purposes, cannot be guarded.

WARNING: Indicates a potentially hazardous situation that, if not avoided, could result in death or serious injury, and includes hazards that are exposed when guards are removed. It may also be used to alert against unsafe practices.

CAUTION: Indicates a potentially hazardous situation that, if not avoided, may result in minor or moderate injury. It may also be used to alert against unsafe practices.

This manual uses the symbols to the right to denote important safety instructions and information.

The **DANGER**, **WARNING** and **CAUTION** symbols are used to denote conditions as stated in the text above. Furthermore, the text dealing with these situations is surrounded by a box with a white background, will begin with **DANGER**, **WARNING**, or **CAUTION**.

The **INFORMATION** symbol is used to denote important information or notes in regards to maintenance and use of the machine. The text for this information is surrounded by a box with a light grey background, and will begin with either **IMPORTANT** or **NOTE**.



DANGER:
Signal word - White Lettering/Red Background
Safety Alert Symbol - White Triangle/Red Exclamation Point



WARNING:
Signal word - Black Lettering/Orange Background
Safety Alert Symbol - Black Triangle/Orange Exclamation Point



CAUTION:
Signal word - Black Lettering/Yellow Background
Safety Alert Symbol - Black Triangle/Yellow Exclamation Point





1.2 Operator - personal equipment

THE OPERATOR

Physical Condition

You must be in good physical condition and mental health and not under the influence of any substance (drugs, alcohol) which might impair vision, dexterity or judgment.

Do not operate a **TORMAX 7216** when you are fatigued. Be alert - If you get tired while operating your **TORMAX 7216**, take a break. Fatigue may result in loss of control. Working with any farm equipment can be strenuous. If you have any condition that might be aggravated by strenuous work, check with your doctor before operating

Proper Clothing



Clothing must be sturdy and snug-fitting, but allow complete freedom of movement. Avoid loose-fitting jackets, scarfs, neckties, jewelry, flared or cuffed pants, unconfined long hair or anything that could become entangled with the machine.



Protect your hands with gloves when handling flail and sections. Heavyduty, nonslip gloves improve your grip and protect your hands.



Good footing is most important. Wear sturdy boots with nonslip soles. Steel-toed safety boots are recommended.



To reduce the risk of injury to your eyes never operate a **TORMAX 7216** unless wearing goggles or properly fitted safety glasses with adequate top and side protection.



Tractor noise may damage your hearing. Always wear sound barriers (ear plugs or ear muffers) to protect your hearing. Continual and regular users should have their hearing checked regularly.



1.3 Machine safety labels

The safety decals located on your machine contain important information that will help you operate your equipment. Become familiar with the decals and their locations.

 **DANGER: TO PREVENT SERIOUS INJURY OR DEATH FROM MOVING PARTS:**

- **KEEP AWAY**, Moving parts can crush and dismember.
- Do not operate without guards and shields in place.
- Disconnect and lockout power source before adjusting and servicing.



6500219

 **DANGER: TO AVOID INJURY:**

- Stay clear of discharge area.
- Stay clear of rotating barrel.
- Wear head, eye, and ear protection.
- Disengage and shut down power source before entering barrel. Use lockout procedures.

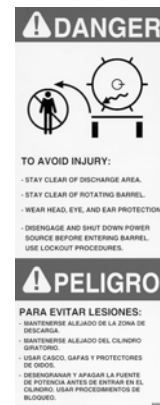

6500227

 **DANGER: TO PREVENT SERIOUS INJURY OR DEATH:**

- Keep hands, feet, and clothing away from auger intake.



6500237

 **DANGER: No open flame. Diesel fuel in this area. Do not overfill. Locate fire extinguisher before filling.**

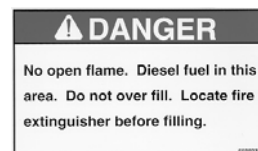

6500238



WARNING: For your protection keep all shields in place and secured while machine is operating. Moving parts within can cause severe personal injury.

	WARNING		ADVERTENCIA
FOR YOUR PROTECTION KEEP ALL SHIELDS IN PLACE AND SECURED WHILE MACHINE IS OPERATING. MOVING PARTS WITHIN CAN CAUSE SEVERE PERSONAL INJURY.		PARA ASEGURAR SU PROTECCION, MANTENGA TODOS LOS PROTECTORES EN SU LUGAR Y ASEGURADOS MIENTRAS LA MAQUINA ESTE OPERANDO. LAS PIEZAS MOVILES INTERNAS PUEDEN CAUSAR LESIONES PERSONALES GRAVES.	

6500040



WARNING: HIGH-PRESSURE FLUID HAZARD

To prevent serious injury or death:

- Relieve pressure on system before repairing or adjusting or disconnecting.
- Wear proper hand and eye protection when searching for leaks. Use wood or cardboard instead of hands.
- Keep all components in good repair.

		WARNING	
HIGH-PRESSURE FLUID HAZARD To prevent serious injury or death:			
<ul style="list-style-type: none"> • Relieve pressure on system before repairing or adjusting or disconnecting. • Wear proper hand and eye protection when searching for leaks. Use wood or cardboard instead of hands. • Keep all components in good repair. 			

6500220



WARNING: FOR YOUR PROTECTION AND SAFETY OF OTHERS, FOLLOW THESE SAFETY RULES.

1. Read and understand operators manual before operating machine.
2. Place all controls in neutral, stop engine, remove ignition key, lock out power source, and wait for all motion to stop before servicing, adjusting, repairing, or unplugging.
3. Read and understand all decals on machine for your safety.
4. Keep all shields in place while machine is in operation.
5. Keep hands, feet, hair, and clothing away from moving parts.
6. Keep others away from machine while in operation.
7. Install safety locks before transporting, or working beneath components.
8. Do not allow riders at any time.
9. Do not leave machine unattended with engine running.
10. Keep all hydraulic lines, couplings, and fittings free of leaks during operation.
11. Keep away from overhead electrical lines. Electrocutation can occur without direct contact.
12. Review safety instructions periodically.

 WARNING	 ADVERTENCIA
FOR YOUR PROTECTION AND SAFETY OF OTHERS, FOLLOW THESE SAFETY RULES.	PARA SU PROTECCIÓN Y LA SEGURIDAD DE OTROS, OBSERVE ESTAS NORMAS DE SEGURIDAD
<ol style="list-style-type: none"> 1. Read and understand operators manual before operating machine. 2. Place all controls in neutral, stop engine, remove ignition key, lock out power source, and wait for all motion to stop before servicing, adjusting, repairing, or unplugging. 3. Read and understand all decals on machine for your safety. 4. Keep all shields in place while machine is in operation. 5. Keep hands, feet, hair, and clothing away from moving parts. 6. Keep others away from machine while in operation. 7. Install safety locks before transporting, or working beneath components. 8. Do not allow riders at any time. 9. Do not leave machine unattended with engine running. 10. Keep all hydraulic lines, couplings, and fittings free of leaks during operation. 11. Keep away from overhead electrical lines. Electrocutation can occur without direct contact. 12. Review safety instructions periodically. 	<ol style="list-style-type: none"> 1. Lea y comprenda el manual del operador antes de operar la máquina. 2. Coloque todos los controles en punto neutro, apague el motor, retire la llave de encendido, cierre la alimentación de electricidad y espere a que se detenga todo el movimiento antes de proceder al servicio, ajuste, reparación o desenchufado. 3. Lea y comprenda todas las calcomanías adheridas a la máquina para su seguridad. 4. Mantenga todas las defensas en su lugar mientras la máquina está en funcionamiento. 5. Mantenga las manos, pies, cabello y ropa lejos de las partes en movimiento. 6. Mantenga a otras personas alejadas de la máquina en funcionamiento. 7. Instale trabas de seguridad antes de proceder al transporte o a trabajar debajo de los componentes. 8. No permita en ningún momento que otras personas viajen en la máquina. 9. No deje a la máquina sin operador con el motor encendido. 10. Mantenga todas las líneas hidráulicas, acoplamiento y accesorios sin fugas durante el funcionamiento. 11. Permanezca alejado de las líneas eléctricas overhead. Puede producirse la electrocución sin contacto directo. 12. Analice las instrucciones de seguridad en forma periódica.

6500208



CAUTION: KEEP WHEEL BOLTS TIGHT

KEEP WHEEL BOLTS TIGHT

MANTENER AJUSTADOS LOS PERNOS DE LA RUEDA

6500042

6500220



1.4 Shielding

The trommel screen is equipped with heavy-duty shielding at major points of potential injury. Shields covering the main sprocket drives should be kept in place at all times. Bodily injury may occur if the unit is operated without shields.

The unit is equipped with an operation and maintenance manual and this manual should be kept in the unit for periodic review by operational personnel. For an illustration, refer to Fig. 3.3.

Operators should be equipped with head, eye and ear protection as well as clothing appropriate for the application. No loose clothing, no unrestrained long hair, or other appurtenances should be allowed on or near the machine.

1.5 Trommel screen safety review

Each and every safety aspect of the DuraTech 7216 trommel screen should be reviewed by each operator on a frequent basis. Safety systems are in place that result in direct operator security.

- **NEVER OPERATE THE UNIT WITHOUT ALL SAFETY FEATURES, INCLUDING SHIELDS, IN PLACE AND IN OPERATING CONDITION.**
- Only one (1) operator at a time should be allowed at or near the machine.
- As most units are equipped with their own power systems, never service any component of the trommel screen without first disconnecting or shutting off the power unit and removing the ignition keys.
- **NEVER ENTER THE SCREW AUGER FEED AREA WITHOUT HAVING FIRST DISCONNECTED OR SHUT DOWN THE POWER SOURCE.**
- Review all safety decals daily.
- In the event the unit is equipped with a power unit such as a diesel engine, wear proper clothing when refueling.
- Do not smoke near the unit when refueling.
- Bleed off any pressurized lines, such as fuel or hydraulic lines, before servicing these systems.
- Do not operate the machine in an enclosed building where exhaust gases are allowed to accumulate.
- Review the exhaust system for any leaks, and repair or replace the system if necessary.
- Deflate tires before removing them from the unit.
- Never leave the vicinity of the unit with the engine running or with the barrel turning.

1.6 Fire safety

Locate a fire extinguisher prior to startup or operation of the unit. When processing any flammable products, always use a water spray system. At shutdown, always clean off the unit using high-pressure air or water. All debris, wood chips, paper, and combustible or ignitable material should be cleaned off the unit. Clean the engine compartment daily or more often as conditions warrant. When cleaning engine compartment, pay particular attention to the top of engine. Never leave the vicinity of the unit with the engine running or with the barrel turning.



1.7 Important safety reminders

- Always follow basic safety precautions when using this unit to reduce the risk of injury.
- **Never** perform maintenance in the barrel without first disconnecting the power source.
- When operating the unit, stay a minimum distance of 6 to 8 feet away from the unit discharge area. Flying debris can possibly injure inattentive personnel.
- Never climb on or crawl under the machine or enter the barrel or feed hopper when the engine is running or the machine is in operation.

1.8 Towing

Check all lights, brakes, safety chains and hitch connections before towing.

A commercial driver's license may be required to tow this unit; verify with traffic control or licensing authorities.

The unit weighs approximately 18,400 lb. and has a high center of gravity. Use caution when traveling on public roads, rough or winding roads, or steep terrain. Never exceed a towing speed of 45 miles per hour.



Section 2: Dealer Preparation

The Tromax 7216 is set up as much as possible at the factory prior to shipping. Typically, the brushes and the hopper extension will need to be installed when the machine arrives at the final destination.

2.1 Brushes

The brushes are attached to the top main frame tube on the left side of the machine. They are held in place with “U” bolts that are included in the shipping kit. After the brush assemblies have been centered on the screens, tighten the “U” bolts. Adjust the brush assemblies so about 1/8 inch of the bristle protrudes inside the screen. This provides adequate screen cleaning and minimizes wear on the brushes.

2.2 Hopper extension

The hopper halves may be joined prior to lifting the extension to the top of the Tromax unit. The hopper halves are joined with two 1/2 x 1-1/2-inch bolts. Use the angle iron spreader bar to keep the extension spaced correctly while lifting the extension to the top of the Tromax mainframe. The angle iron spreader bar should be placed over the barrel drive cover plate. The hopper extension is bolted to the top of the mainframe with four 1/2 x 7-inch bolts.



NOTE: Installation of the hopper extension will make the Tromax unit nearly 11 feet wide, and may require removal for transport on public roadways. Check with state authorities for details.

2.3 Adjustable feed control plates

If adjustable feed control plates are to be added to the Tromax unit, they may be installed at this time. Place the plates over the studs on the hopper extensions and secure with the flat washers and nuts provided.

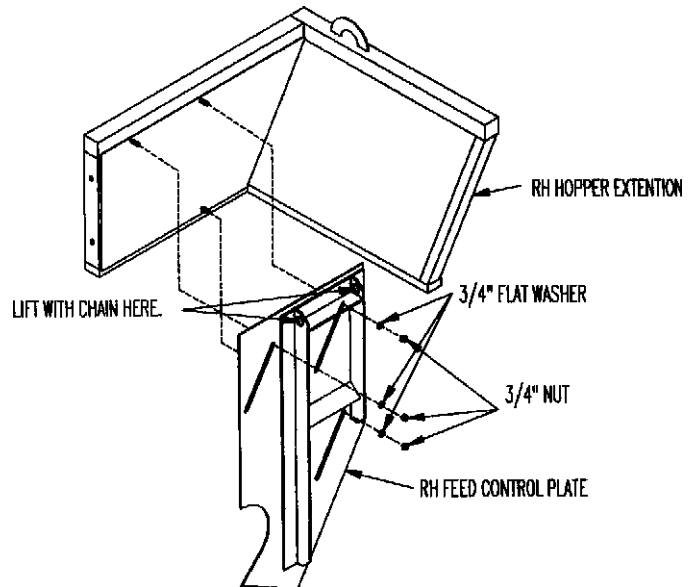

Feed control plate installation



2.4 Side gathering conveyor

Some machines are ordered with a side gathering conveyor in place of the side apron. The side gathering conveyor fits against the right side of the Tromax unit with the open side of the conveyor facing toward the unit.

Use 5/8 x 5-inch bolts to mount the conveyor in the brackets normally used for the side apron. Use 5/8 x 8-inch bolts and the channel-shaped brackets to clamp the top of the conveyor to the Tromax unit. Be certain that the rubber belting seals lay against the Tromax frame so material slides easily into the side conveyor with minimal leakage.

More detailed assembly instructions are included in the shipping kit for field installation of the side gathering conveyor.



NOTE: Installation of the side gathering conveyor and the hopper extension will make the Tromax over 12 feet wide, and may require removal for transport on public roadways. Check with state authorities for details.

2.5 Predelivery inspection

- Perform a thorough predelivery inspection of the Tromax 7216 trommel screen unit.
- Lubricate all bearings. Refer to Section 5.2, “Bearing and chain lubrication.”
- Check engine oil level. Refer to Section 4.2, “Engine lubrication requirements,” and to the Isuzu engine operation and maintenance manual.
- Check engine coolant level. Refer to Section 4.3, “Engine coolant requirements,” and to the Isuzu engine operation and maintenance manual.
- Check battery electrolyte levels and verify that cable connections are secure.
- Check hydraulic fluid level. Refer to Section 5.4, “Hydraulic system.” The hydraulic system includes a pressure relief valve that is preset at the factory; it should not require further adjustment.
- Check diesel fuel level. Refer to Section 4.1, “Diesel fuel requirements,” and to the Isuzu engine operation and maintenance manual.
- Check that there are no fuel or hydraulic leaks.
- Check barrel drive chains for alignment.
- Check that all shields are in place.
- Check that brushes are adjusted so bristles are approximately 1/8 inch into the screens.
- Check tightness of hitch mounting bolts and verify that cotter pins are installed.
- Check electric brakes for proper operation.
- Check tires for proper inflation pressure (125 psi cold).



2.6 Engine operation check

- Start the engine and check for normal operation. Refer to Section 3.3.5, “Operation and care of a new engine,” and to the Isuzu engine operation and maintenance manual.

If the engine fails to start, refer to Section 3.3.7, “If the engine fails to start.” DO NOT use starting aids such as ether.

The engine will automatically shut down if it overheats or if engine oil pressure is inadequate. If this happens, refer to Section 3.3.9, “Automatic engine shutdown system.”

- Test throttle operation. Refer to Section 3.3.8, “Throttle operation.” Observe engine break-in recommendations in Section 3.3.5, “Operation and care of a new engine.”

2.7 Trommel screen operation check

- Check that the stripper blades on the barrel clear the stripper sheets.
- Check that the barrel drive chain is running in alignment with sprockets and the idler.
- Start the trommel screen and check for normal operation. Refer to Section 3.3.10, “Starting the trommel screen.”



Section 3: Operation

This section describes the main components of the Tromax 7216, how to operate the Tromax 7216 trommel screen system, and how to optimize the 7216's performance.

Figure 3.1
Side view showing apron in open working position

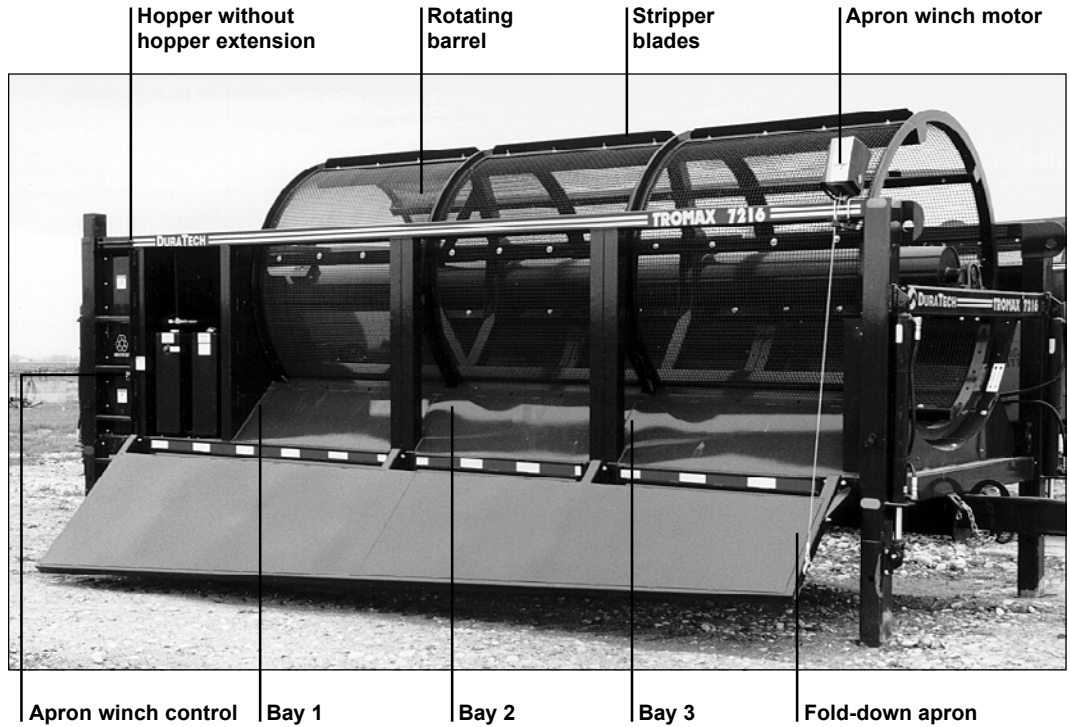
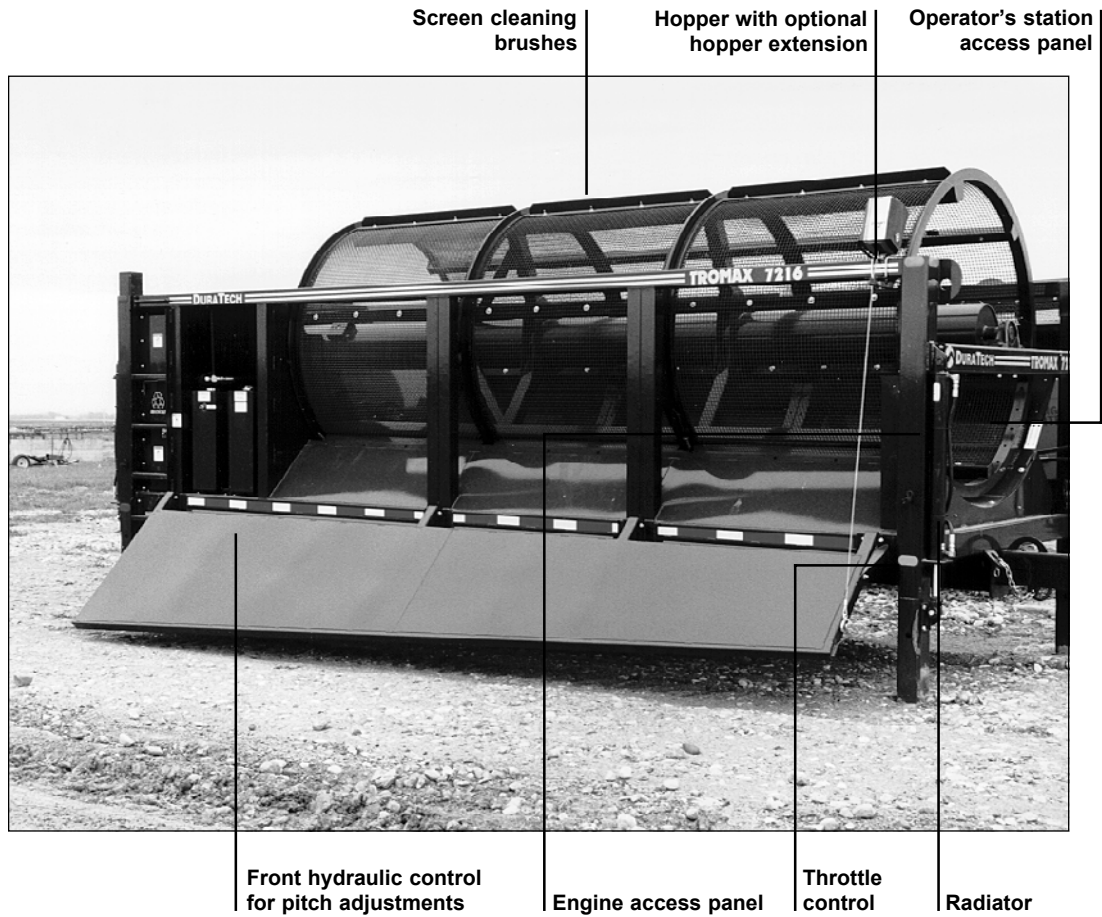

Figure 3.2
Side view showing operator's station and brushes





3.1 Description of the Tromax 7216 trommel screen

The Tromax 7216 trommel screen unit was designed and developed to provide a mechanism for sizing and separating a wide variety of substances and materials. The unit incorporates a number of basic features including the rotating barrel itself, the stripper blades affixed to the outside of the rotating barrel, the stripper sheets located beneath the barrel, the screw auger feed mechanism, the feed auger hopper, gear box drive system, the fold-down apron, and the axle and hitch assemblies.

Material is fed into the hopper of the unit by an appropriate means, either a bucket-type wheel loader or the discharge conveyor on a tub grinder. Material is fed into the hopper onto the screw augers, which act to feed the material into the rotating barrel.

Due to the acute angle of the barrel, material feeds towards the discharge end. During this transition from the feed to the discharge end, material fraction is sifted through the screens and subsequently is stripped off the stripper sheets by the stripper blades which are rotating on the periphery of the barrel.

When equipped with the fold-down apron, material can be gathered via a bucket more easily than if material had to be retrieved directly underneath the rotating barrel.



NOTE: When reference is made as to front, rear, left hand, or right hand of this machine, the reference is always made from standing at the rear end of the machine and looking toward the hitch.

3.2 Description of the Tromax 7216's major components

3.2.1 Stripper blades

Stripper blades are attached to the outer periphery of the barrel and serve to push the screened material from below the barrel to the discharge side of the machine. They also assist in holding the screens in place.

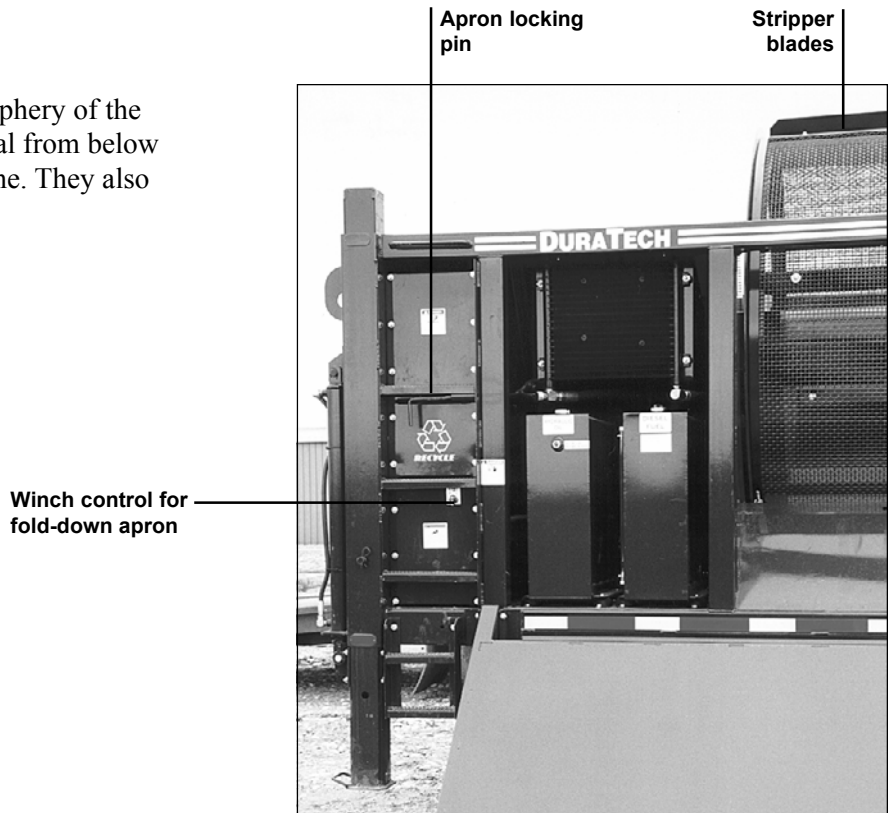

Stripper blades and controls



3.2.2 Stripper sheets

The stripper sheets located underneath the barrel consist of stripper sheets 1, 2, and 3 respectively, counting from the auger end to the discharge end. The stripper sheets will occasionally require replacement. Refer to **Part 2, Parts Reference**, for correct part number.

3.2.3 Screens

A variety of screens are available for the trommel screen unit. Standard equipment is 5/32-inch wire with 3/4-inch openings in the screen. Each segment requires three screens bolted in place. Pay close attention to the equipment drawings included in this manual to insure that the screens are “lapped” correctly when they are installed.

3.2.3a What can and can't I screen?

The Trommel Screen unit was designed to allow screening of most organic type material including compost, wood waste, ground-up construction demolition debris, many types of soils, and salt. However, it is not designed to screen aggregates such as rock and gravel.

Material is fed into the system at the auger end of the machine and tumbled towards the discharge end. In most applications, material, once sifted through the screen to the lower stripper plate area, will be discharged to the side of the machine by the paddles mounted on the rotating barrel. In some cases, due to the type of material or size of the screen, material may become lodged between the screen and the stripper sheets. In this situation, the stripper sheets will have to be removed and the material allowed to discharge beneath the machine.

As with all rotating-type screens, production is based on three factors.

- Size of screen opening.
- Angle of the barrel.
- Speed at which the barrel is turning.

Thus, there are a wide number of variables that come into play in determining what your overall efficiency and performance will be. Some experimentation will be required on your part to determine what is the best combination.

3.2.3b Screen sizes

As standard equipment, the unit is furnished with 8-gauge, (5/32-inch) wire with 3/4-inch openings. A wide variety of special screen sizes can be made available. Generally wire cloth is used; however, punched sheet-type screens are also available.



CAUTION: Care should be taken when operating the unit with opening sizes larger than 1.5 inches. Opening sizes larger than this can allow spears and other oversized material through the screen, causing jams between the screens and the stripper sheets.



3.2.4 Feed augers

The feed augers are driven via a chain system that turns when the barrel turns. The augers are affixed to a steel tube that is subsequently slid over a stress-proof shaft. These auger segments are then affixed to this shaft with a shear bolt located near the end of the auger. The augers are counter-rotating. Review the equipment drawings in this manual to insure the roller chain is installed properly.

3.2.5 Apron

As optional equipment, the Tromax 7216 trommel screen unit may be equipped with a fold-down apron system with struts. This apron allows easy access to sized material by providing a backstop for the material. Always use the brace struts when operating the trommel screen with the fold-down apron. Do not push against the apron without having the struts in place. The apron is raised and lowered with an electric winch. The fold-out fork holds the cable away from the apron to decrease strain on the cable when lifting the apron. Fold out just prior to lifting apron.

3.2.6 Gear box and chain drive system

The unit is equipped with a heavy-duty oil-filled planetary-type gear box and is continuously lubricated via the hydraulic system. The final drive on the main barrel is #100 roller chain. The auger drive chain is #80 roller chain. Lubrication of the chain should be completed every 40 hours. All rotating shaft members are operating in regreasable-type bearings. These bearings should be greased every 40 hours.

3.2.7 Brushes

The unit may include rotating polyethylene brushes to keep the screens clean. These brushes are located above the rotating barrel and are equipped with a threaded stop bolts. Adjust stop bolts so brush tips extend 1/8 inch or less through the screen.

Brush adjustment

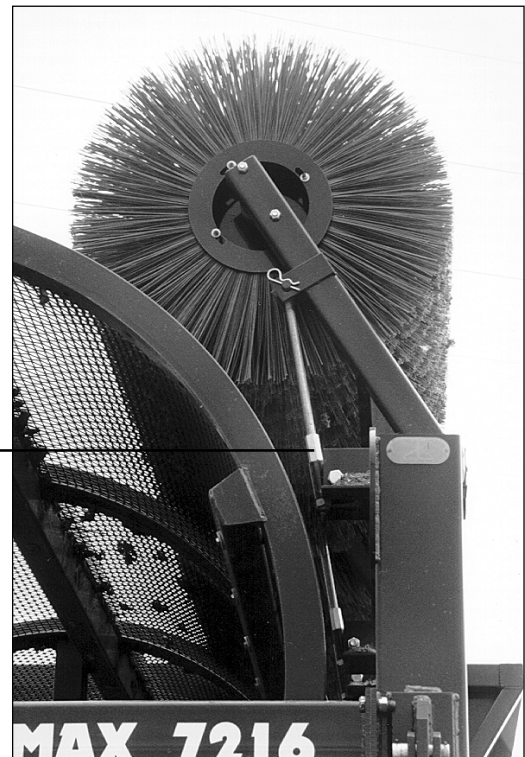



3.2.8 Operator controls

The operator controls are pictured below:

Fig. 3.3
Operator controls

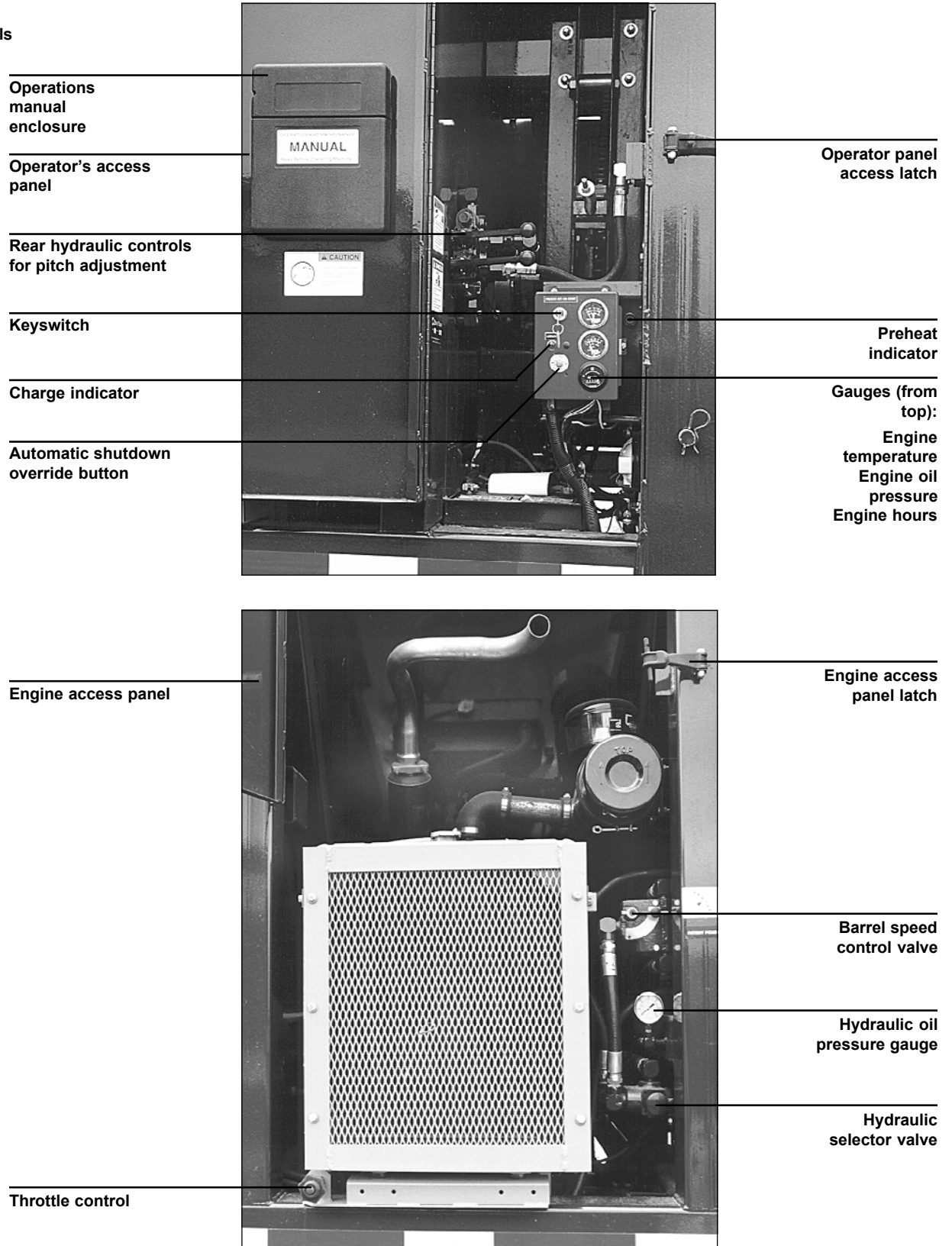



3.3 Operation

This section describes how to operate the Tromax 7216 trommel screen system, as well as how to optimize its performance.

3.3.1 Daily preoperation inspection

Before operating the Tromax 7216 trommel screen, perform an inspection that includes the following items. As each task is performed, check or initial the adjacent box.

- Lubricate all bearings according to the instructions in section 5.2.
- Check engine oil level.
- Check engine coolant level.
- Make sure the radiator is not plugged with debris or dust. If it is, clean it to avoid engine overheating.
- Check battery fluid levels and verify that cable connections are secure.
- Check hydraulic fluid and diesel fuel levels.
- Make sure there are no fuel, hydraulic fluid or coolant leaks.
- Check barrel and auger drive chains for proper tension, lubrication and alignment.
- Check that paddles on barrel clear the stripper sheets and the side dust sheets.
- Check for any loose or missing bolts or other hardware not in place. These should be tightened, replaced or repaired.
- Make sure all shields are in place.
- Make sure no material has been allowed to build up around or under the unit.
- Check the entire machine before starting the engine to insure that no personnel are servicing or repairing the machine.



3.3.2 Hitching to a tow vehicle

The Tromax 7216 trommel screen weighs approximately 18,400 pounds, depending on the optional equipment installed. The hitch weight can exceed 4,000 pounds. Be certain the tow vehicle has sufficient ratings and braking capacity for this load. An electric brake controller is required on the tow vehicle. A standard six-pin connector is required for trailer lighting and electric brakes.

Three hitch configurations are available on the 7216 trommel screen. A pintle hitch is the standard hitch. A gooseneck hitch can be ordered with a 2-5/16-inch ball coupling, or with an adapter to connect to the fifth wheel plate on a semi tractor.

To hitch the Tromax 7216 to a towing vehicle, perform the following steps:

1. Insert the hitch into the receiver on the trommel screen frame. Install retaining pins and secure with hairpins. (A wheel loader or other suitable lifting device will be required to lift the hitch to the trommel screen receiver.)
2. Connect safety chains.
3. Connect the wiring harness from the hitch to the trommel frame
4. Connect the brake system breakaway switch to the hitch.
5. Raise the discharge end of the trommel unit sufficiently to clear the tow vehicle hitch.
6. Back the tow vehicle to the hitch and close the couplings to attach the trommel screen to the tow vehicle.
7. Attach safety chains to the tow vehicle.
8. Connect the wiring harness to the tow vehicle.
9. Connect the brake system breakaway switch to the tow vehicle.
10. Raise all drop legs and jacks, and secure in raised position with pins provided.
11. Test the trailer lights for proper function.
12. Test the electric brakes for proper function.
13. Check tires for proper inflation pressure (125 psi cold).
14. Carefully check for clearance between tow vehicle and machine when turning.



pintle hitch



3.3.3 Disconnecting from a tow vehicle

To unhitch the machine from a towing vehicle, perform the following steps.

1. Choose a level site with adequate room to maneuver around the trommel screen for loading as well as removing the screened material and covers.
2. Park the trommel screen in position and block the transport wheels.
3. Remove the lock-up pins from the drop legs and lower the drop legs to the ground.
4. Release the coupling from the tow vehicle.
5. Raise the machine sufficiently to clear the hitch on the tow vehicle and pin the drop legs in place.
6. Disconnect the safety chains, trailer wiring harness, and brake system breakaway switch from the towing vehicle.
7. Drive the tow vehicle away.
8. Disconnect the safety chains, wiring harness, and brake system breakaway switch from the trommel hitch.
9. Unpin the hitch from the trommel receiver and remove the hitch from the trommel screen frame. (A wheel loader or other suitable lifting device will be required to lift the hitch from the trommel screen receiver.)
10. Fold out the apron using the electric winch, and allow the apron to rest on the ground.
11. Raise the hopper end of the trommel screen until the apron hangs vertically.
12. Pin the drop legs on the hopper end of the trommel screen and secure with hairpins.
13. Adjust the discharge end of the trommel screen until the lower edge of the apron is parallel with the ground.
14. Pin the drop legs on the discharge end of the trommel screen and secure with hairpins.
15. Install the two brace struts under the trommel screen frame and to the lower edge of the apron.



Drop leg pin

Hydraulic controls



3.3.4 Hopper loading requirements

The Tromax 7216 trommel hopper will hold up to 3-1/2 cubic yards of material when the hopper extension is used. The width at the top of the hopper extension is 9-3/4 feet and the loading height is approximately 10 feet. Use a suitable means to place material in the trommel hopper, such as a wheel loader or a conveyor. If your loader cannot clear the required height is, construct a small earth ramp at the hopper end of the trommel screen to provide the loader sufficient reach.

3.3.5 Operation and care of a new engine

The Isuzu diesel is tested and adjusted at the engine factory but a thorough break-in period of 100 hr.s is recommended for long engine life.

- Do not race the engine until a warm-up period of 10 minutes has elapsed.
- Do not rapidly accelerate the engine after warm-up.
- Reduced throttle settings (2/3 throttle) are recommended during the break-in period.

3.3.6 Engine starting

To start the engine, perform the following steps:

1. Make certain that the hydraulic control lever is in the neutral (centered) position and the flow control valve is reduced to the "0" setting (fully clockwise).
2. Insert the key into the key switch.
3. Rotate and hold the key to the counterclockwise position to preheat the engine. Hold the key until the preheat indicator begins to glow. Release the key.
4. Shout the word "**CLEAR**".
5. Depress and hold the automatic shutdown override button and turn the key clockwise to crank the engine. Do not crank for more than 10 seconds.
6. When the engine begins to run, release the key but continue to hold the automatic shutdown override button until the oil pressure warning light switches off. Release the override button.
7. Allow the engine to run at idle speed for 10 minutes to allow adequate warm-up.



3.3.7 If the engine fails to start

If the engine doesn't start on the first try, perform the following steps:

1. Allow a 30-second rest period before attempting to restart.
2. Rotate and hold the key to the counterclockwise position to preheat the engine. Hold the key until the preheat indicator begins to glow. Release the key.
3. Shout the word "**CLEAR**".
4. Depress and hold the automatic shutdown override button and turn the key clockwise to crank the engine. Do not crank for more than 10 seconds.
5. If the engine fails to start, contact a qualified diesel mechanic for further advice.



CAUTION: Do not use starting aids such as ether.

3.3.8 Throttle operation

- To increase throttle speed slowly, turn the throttle knob counterclockwise rather than pulling the knob straight out.
- To decrease throttle speed, turn the knob clockwise.
- During the break-in period increase throttle setting slowly to no more than 2/3 of the maximum throttle setting.
- After the break-in period, the engine should be operated at full throttle to produce rated horsepower.
- For emergency slowdown, depress and hold the lock button in center of the throttle knob and push the throttle knob straight in.



3.3.9 Automatic engine shutdown system

The engine will automatically shut down if it overheats or if engine oil pressure is inadequate. If this happens, perform the following steps:

- Check oil level in crankcase.
- Inspect radiator and clean if necessary.
- Check tension and condition of fan belt.
- Allow engine to cool and check coolant level.
- Attempt to restart engine following the normal starting procedure.
- If the engine will not continue running, contact a qualified mechanic.

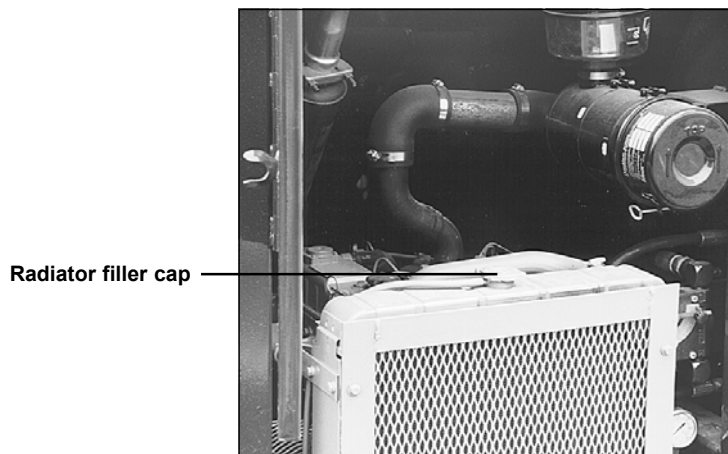

CAUTION: Cover the radiator filler cap with a thick rag and open the cap very slowly to release internal steam pressure. Allow the system to completely depressurize before fully removing cap.



CAUTION: Do not breathe exhaust gas because it contains carbon monoxide. Carbon monoxide is an odorless, colorless gas which, if breathed, can cause unconsciousness and death. Do not run the engine in confined areas, such as garages or shops.

3.3.10 Starting the trommel screen

To start the trommel screen, perform the following steps:

1. As described above, inspect the entire unit prior to starting the engine.
2. Be certain that the barrel speed control valve is in the “0” position (control lever horizontal).
3. Start the engine and, as per the engine manufacturer’s recommendations, allow it to warm up for 10 minutes.
4. Shift the hydraulic selector valve, located just below the pressure gauge, by pulling out on the knob.
5. Set engine throttle to full speed.
6. Initiate barrel rotation by moving the barrel speed control valve clockwise until desired barrel speed is obtained.



3.3.11 Setting barrel speed

Ideal barrel speed should carry the material to a point near the top of the barrel where it can fall the greatest distance to the bottom. This provides the greatest agitation and breaks up lumps to the greatest degree. If the product being screened is fragile, reduce the barrel speed until desired agitation is obtained.

3.3.12 Evaluating sized material

The trommel barrel can be equipped with all screens of the same size, or each of the three bays can contain a separate size. In some situations the first two bays will produce material of the desired size but the last bay will have oversize products and sticks due to spiking. In this situation, it may be beneficial to install a smaller screen in the third section the trommel barrel to prevent spiking. For example, equip the first two sections of the barrel with 1/2-inch screens and the last section with a 3/8-inch screen.

By equipping the first section of the barrel with a fine screen and going progressively coarser in each section, a separate graded product can be obtained from each section of the barrel. Set up walls, such as sheets of plywood, between each section to keep the graded product separated. This feature is unique to the Tromax design with the side discharge. Competitive models with conveyors located below the barrel can't grade a separate product from separate sections of the barrel because all sized product falls to a common discharge conveyor.

3.3.13 Setting trommel screen pitch

The time that a product is retained in the trommel screen is determined by the angle or pitch of the barrel. As a starting point, set the pitch to match the lower edge of the side apron when it is folded down and secured with the struts. To reduce retention time, raise the hopper end. To increase retention time, raise the discharge end.

3.3.14 Replacing the screen

To replace a screen, perform the following steps:

1. Shut down using the normal shutdown procedure found in Section 5.16.
2. Place the machine under a hoist capable of lifting at least 150 lb.
3. Two persons are required to change screens, one person inside and one person outside of the barrel.
4. Remove the screen band clamps.
5. Manually rotate the barrel until a screen section is on the top of the barrel.
6. Remove both stripper blades that clamp the top screen section.
7. Remove top screen section with hoist and replace with new screen section.
8. Secure new screen section with the stripper blades but use only two bolts per stripper blade to hold the screens in place until all sections are replaced.
9. After all top screen sections have been replaced, manually rotate the barrel 1/3 turn and repeat the process until all screen sections have been replaced.
10. After all screen sections have been replaced, insert all bolts into the stripper blades and secure with lock nuts.
11. Replace the screen band clamps and tighten.



3.3.15 Unplugging and restarting the trommel screen

In the event that the Trommel Screen becomes plugged or jammed, shut the system off and remove the key. The hydraulic system on the Tromax 7216 trommel screen does not allow for the unit to be rotated opposite its normal direction. If you attempt to do so, severe damage can result to the chain idler assemblies in the main drive area. **DO NOT** enter the machine until the engine is shut off, the key is removed from the ignition and all movement has stopped.

Remove material from beneath the screen. If spears, sticks or other materials protrude through the screen, you may need to enter the barrel and pull them out from the inside. In the event that something jams in the augers, you will need to enter the feed hopper and dislodge the material at this point.

It should be noted that the hydraulic system is equipped with a pressure relief valve. This relief valve should be set to a level that allows proper functioning of the barrel, but not so high as to remove its function as the “system relief.” If something becomes jammed in the screen or auger area, the pressure relief valve should release oil over the pressure relief valve without stalling the engine.



IMPORTANT: Do not set the pressure relief valve at such a level that, in the event that something becomes jammed in the system, the engine stalls. Under no circumstances exceed a relief valve setting of 2,500 psi, or severe damage to components will result.

3.3.16 Normal shutdown

Use the following procedure to shut down the trommel screen under normal operation:

1. Allow material to feed out of the feed hopper and proceed through the barrel.
2. Reduce the setting of the flow control valve to approximately 2 and allowed to run for 2 to 3 minutes.
3. Set the flow control valve to “0”.
4. Allow the engine to idle for 2 to 3 minutes.
5. Shut down the engine and remove the key.

3.3.17 Emergency shutdown

Use the following procedure to shut down the trommel screen in an emergency:

1. Set the flow control valve to “0”.
2. Shut down the engine and remove the key.



Fig. 3.4
Shutdown controls

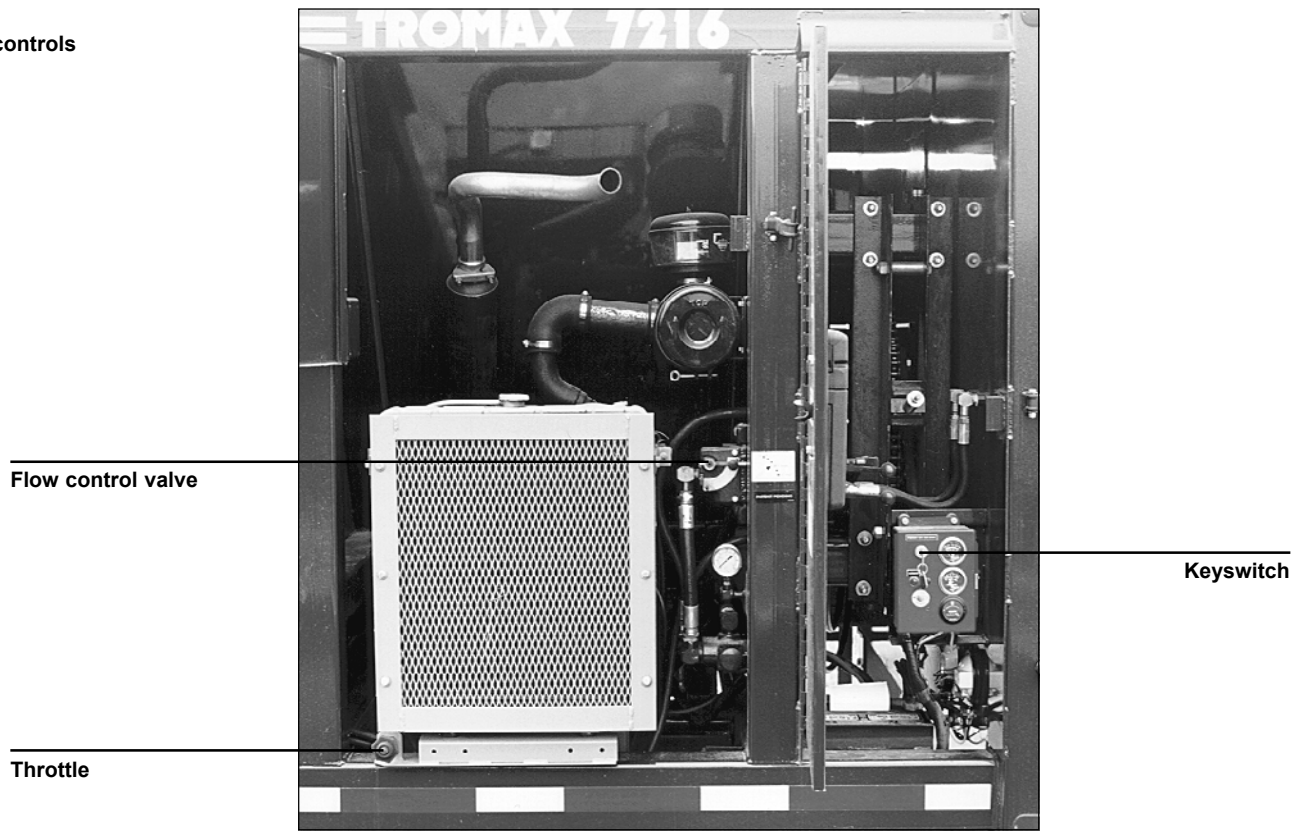



Section 4: Engine Maintenance

Every effort should be made by the operator of the Tromax 7216 trommel screen to complete all maintenance routines on time, paying particular attention to lubrication. An established maintenance routine results in long-term efficiency and economy.

This section contains highlights from the Isuzu engine operation and maintenance manual. For more detailed information, review the Isuzu manual.

Fig. 4.1
Engine bay

Exhaust pipe

Precleaner bowl

Air filter

Oil filler cap

Oil dipstick

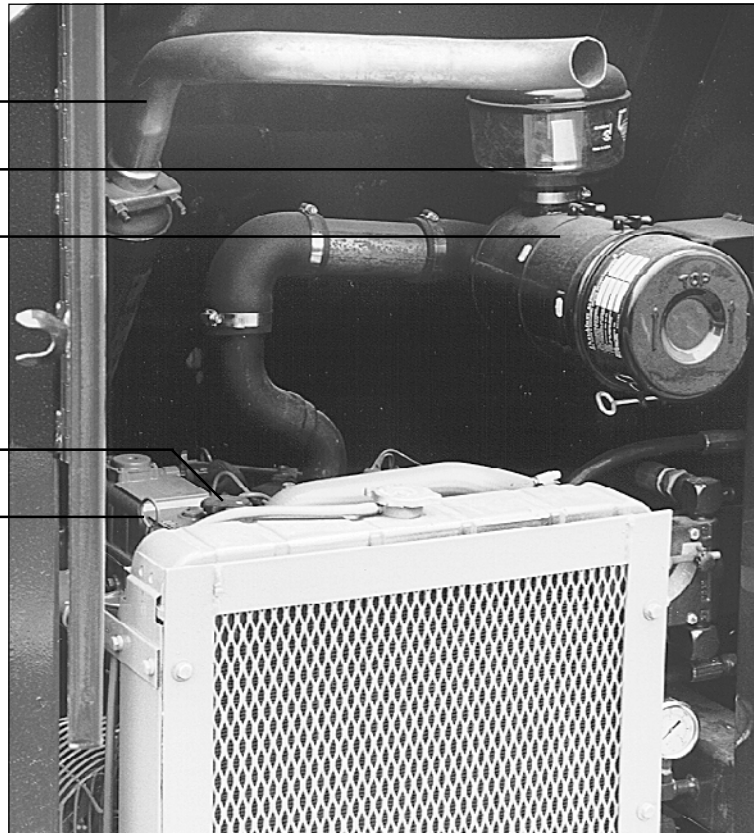

4.1 Diesel fuel requirements

The engine is designed to use Number 1-D or Number 2-D diesel fuel. The use of Number 2-D is preferred for normal operating conditions. If you plan to operate at atmospheric temperatures of 20 degrees F (-7 degrees C), use a “winterized” blend of Number 1-D and Number 2-D diesel fuel.

- Do not use heating oil or gasoline as fuel or engine damage may result.
- Do not use diesel fuels that have been blended with used engine oil.
- Check with your fuel supplier to be sure of the quality of fuel you are buying.
- Take care to prevent contaminants such as dust or water from entering the fuel tank while fueling.
- There is some water found in diesel fuel which will pool at the bottom of the fuel tank. This water should be drained periodically.
- Change engine fuel filter every 500 hours of operation.

See the Isuzu engine operation and maintenance manual for further details



4.2 Engine lubrication requirements

The quality of engine oil may have a large effect on engine performance, startability and engine life. Use engine oil with an API CC or CD rating. Engine oil viscosity should be selected in accordance with the prevailing atmospheric temperatures.

- Change engine oil and oil filter after the first 50 hours of operation and every 250 hours thereafter.
- Drain oil while the engine is warm, but after engine has cooled sufficiently to avoid burns.
- Wipe all contaminants away from the oil filter, drain plug and oil filler cap before beginning the oil change procedure.

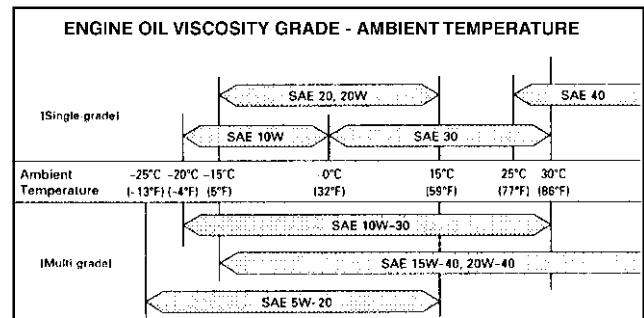

Engine lubrication requirements

- When installing a new filter, lightly oil the “O” ring and turn in until the “O” ring contacts the sealing surface. Use an oil filter wrench and tighten the cartridge by 3/4 turn.
- Engine oils with the API CC or CD ratings contain all the necessary additives for proper lubrication in this engine. Using additional additives is not recommended.
- Do not mix different brands of oil or different quality oils.
- See the Isuzu engine operation and maintenance manual for further details

4.3 Engine coolant requirements

- A 50/50 blend of ethylene glycol-based antifreeze is recommended.
- The coolant should be drained and replaced with fresh coolant every six months.
- The cooling system should be flushed at least every 1,000 hours of engine operation.
- See the Isuzu engine operation and maintenance manual for further details.

4.4 Fan belt tension

- Proper belt tension is indicated when the belt can be depressed approximately 3/8 inch with firm thumb pressure midway between the fan pulley and the generator pulley.
- See the Isuzu engine operation and maintenance manual for further details.



4.5 Air cleaner

- A dirty air cleaner can cause reduced engine output and reduced engine life. The engine is equipped with an air filter restriction indicator, which is found between the air filter housing and the engine intake manifold. The filter is normal when the indicator is green and requires service when the indicator turns red.
- A bowl type precleaner is located in the upper right corner at the rear of the engine compartment. The bowl should be emptied daily or more frequently if conditions warrant. Inspect the flexible tubing between the precleaner bowl and the filter on a monthly basis and replace if damage is apparent. Small leaks will not damage the engine but will shorten the service life of the air filter element.

4.6 Operation and care of a new engine

The Isuzu diesel is tested and adjusted at the engine factory but a thorough break-in period of 100 hr. is recommended for long engine life.

- Do not race the engine until a warm-up period of 10 minutes has elapsed.
- Do not rapidly accelerate the engine after warm-up.
- Reduced throttle settings (2/3 throttle) are recommended during the break-in period.

4.7 If the engine fails to start

- Allow a 30 second rest period before attempting to restart.
- Rotate and hold the key to the counterclockwise position to preheat the engine. Hold the key until the preheat indicator begins to glow. Release the key.
- Shout the word “CLEAR”.
- Depress and hold the automatic shutdown override button and turn the key clockwise to crank the engine. Do not crank for more than 10 seconds.
- If the engine fails to start, contact a qualified diesel mechanic for further advice.
- Do not use starting aids such as ether.

Section 5: General Maintenance

5.1 Checking battery condition

Check the condition of the battery to insure that the electrolyte level is correct, that the terminals and cables are not corroded or misrouted, that the battery is held in place properly, and there is no arcing or grounding by the terminals. The system uses a 12-volt battery with a negative ground system.

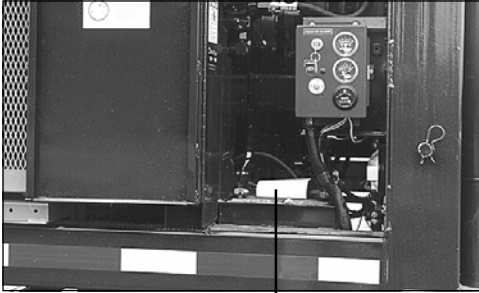

Battery housing



CAUTION: Gas given off by battery is explosive. Keep sparks and flames away from battery. Before connecting or disconnecting a battery charger, turn charger off. Make last connection and first disconnection at a point away from battery. Always connect NEGATIVE (-) cable last and disconnect this cable first.

5.2 Bearing lubrication

Grease the bearings located on the outside at the rear of the unit (four bearings), and the 3 lube points indicated in fig. 5.1 then proceed to the auger hopper and grease the barrel shaft bearing at this location. Proceed around to the discharge end of the machine and grease the barrel pillow block bearing on the barrel shaft end.



NOTE: Remove the engine key before proceeding to enter the hopper for maintenance. Check to insure that no oversized or excess material has compacted between the screen and the stripper sheets. If the unit is in the raised position, check to insure that the drop leg lock pins are in place. Never allow the feed or auger end of the unit to be raised and left in the raised position by the hydraulic lift cylinders, if so equipped, by themselves. When the unit is raised, the lock pins must always be in place in the drop legs.

Fig. 5.1
Main drive bearings

Lubrication points (3)





Fig. 5.2
Barrel shaft

Lubrication point

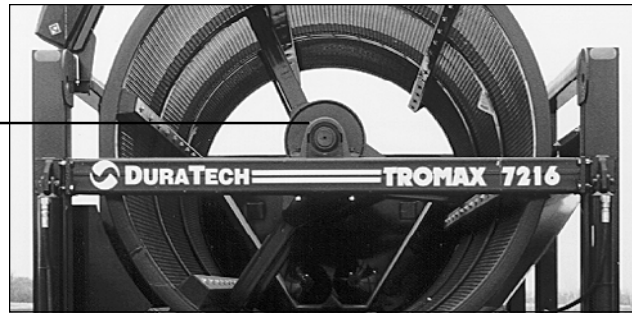
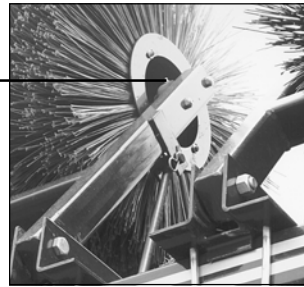

Fig. 5.3
Cleaning brush shaft

Lubrication point



Bearings operating in the presence of dust and water should contain as much grease as speed will permit, since a full bearing with a slight leakage is the best protection against entrance of foreign material. In the higher speed ranges, too much grease will cause overheating.

When operating during cold weather, all lubrication should be performed after bearings are at operating temperatures.

Any bearing operated at high speed and at abnormal bearing temperature may indicate faulty lubrication. A bearing operating under normal conditions should feel cool to warm to the touch. Unusually high temperatures, too hot to touch for more than a couple of seconds, accompanied by excessive leakage of grease at the seals, indicates too much grease. High temperatures with no grease showing at the seals, particularly if the bearing seems noisy, usually indicates too little grease. Normal temperature and a slight showing of grease at the seals indicate proper lubrication.

A heavy-duty, lithium-based, general-purpose grease is recommended for lubricating the trommel screen.

5.3 Auger maintenance

The trommel screen is equipped with counter-rotating 12-inch diameter feed augers. This system allows material to be fed into the unit with virtually no bridging or tunneling. Some wear can be expected on the augers, however, and they are easily replaced. The augers, both left and right, are mounted on pipes, which slip over the auger shafts. They are fixed with a 1/2-inch bolt.

The augers can be removed easily and built up with nickel welding rod, if the application so requires. Do not allow the augers to become bent in the event that something becomes wedged in them. Bent augers are extremely detrimental to the system's feeding efficiency.



5.4 Hydraulic system

The unit has a large-capacity hydraulic oil reservoir with a combination filler/breather cap. Always check the hydraulic oil level, as marked on reservoir, before starting the unit. Fill to fluid level as required. The unit has a screw-on type hydraulic oil filter, which should be changed after the first 20 hours of operation and then every 100 hours thereafter.



Check the hydraulic oil regularly, and if the oil has a burnt smell or milky appearance, change it immediately.

DuraTech Industries recommends using Conoco Hydroclear Power Tran Fluid if your machine has a Hydroclear decal on the hydraulic tank. Other acceptable fluids include Mobil 423, Farmland Super HTB, or other similar fluids. If the hydraulic tank does not have this decal, then all of the above fluids are acceptable.

The unit has an open-center hydraulic system as noted on the piping diagram. Fluid is drawn from the oil reservoir through the pump and to the selector valve. A pressure relief valve is located in the line between the hydraulic pump and the selector valve.



CAUTION: Under no circumstances should the pressure relief valve be set higher than 2,500 psi, or severe damage to the system could result.

Fluid is routed either to the two-spool valve, which controls the drop legs, or to the flow control valve, which serves the barrel and auger drive. The system also includes a hydraulic oil cooler and fan assembly, and a return line oil filter.

The system **does not** include a high-temperature hydraulic oil shutdown system. Care should be taken to insure that the hydraulic oil cooler is free of dust and debris at all times.

Figure 5.4
Hydraulic and diesel fuel
reservoirs

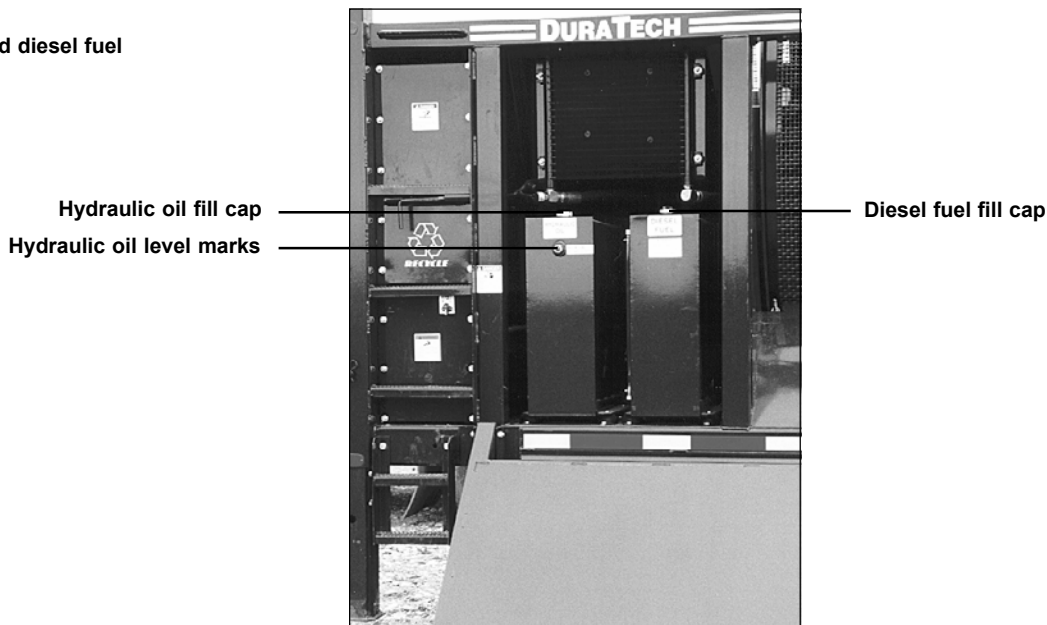



5.5 Axles, wheels and tires

The axle should be inspected before the machine moves to make sure that the bolts holding the leaf springs to the axles are tight, and that the leaf springs show no breakage or abnormal wear. Check the oil level in the hubs, and add if necessary.

Inspect the tires to insure there is sufficient tread and no cuts or abrasion marks on the tires. The air pressure should also be checked. Proper inflation pressure is 125 psi. Make sure that the wheel lug nuts are properly torqued.

Before moving the unit, check the brakes to insure that they are functioning. Once the vehicle is hooked to the trommel screen, the brakes should be rechecked before moving the unit onto public thoroughfare.

Use safety chains when hitching the unit to a towing vehicle.

Figure 5.5
Dexter 15,000 lb. wheel and hub assembly

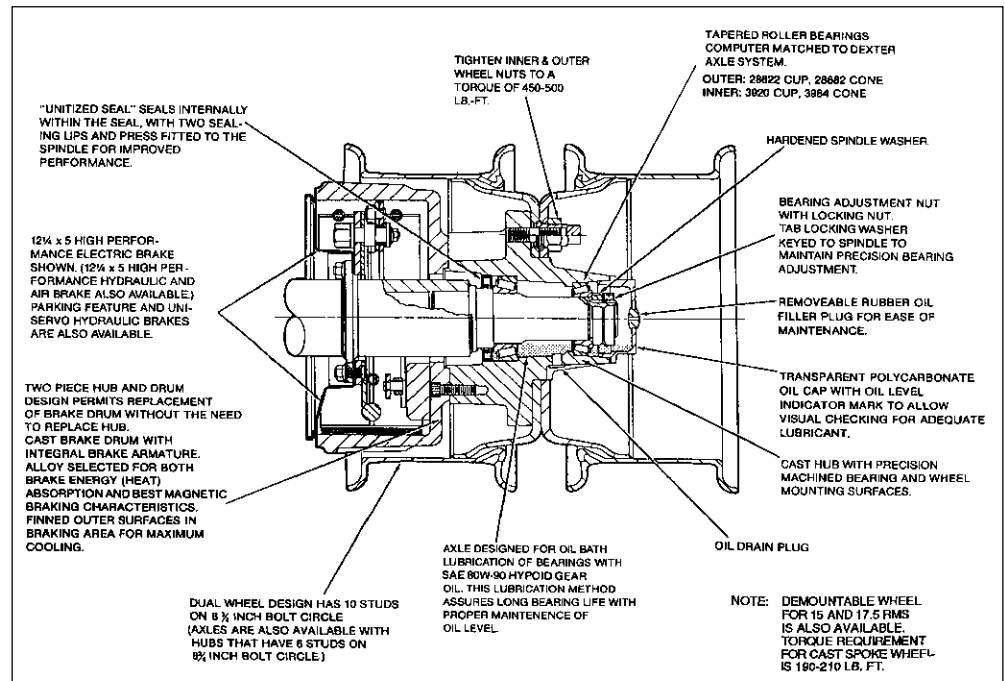

5.6 General appearance

Clean the unit frequently with high-pressure air or water in order to make the inspection process easier. Leaking hoses and loose fittings or fasteners are much more easily observed on a clean machine. Use no solvents to clean the unit.



Appendix A: Warranty

DuraTech Industries International Inc. warrants to the original purchaser for 12 months from purchase date that this product will be free from defects in material and workmanship when used as intended and under normal maintenance and operating conditions. This warranty is limited to the replacement of any defective part or parts returned to our factory in Jamestown, North Dakota, USA, within thirty (30) days of failure.

This warranty shall become void if in the judgment of DuraTech Industries International, Inc. the machine has been subject to misuse, negligence, alterations, damaged by accident or lack of required normal maintenance, or if the product has been used for a purpose for which it was not designed.

All claims for warranty must be made through the dealer which originally sold the product and all warranty adjustments must be made through same.

This warranty does not apply to tires or bearings or any other trade accessories not manufactured by DuraTech Industries International Inc. Buyer must rely solely on the existing warranty, if any, of these respective manufacturers.

DuraTech Industries International Inc., shall **not** be held liable for damages of any kind, direct, contingent, or consequential to property under this warranty. DuraTech Industries International Inc., cannot be held liable for any damages resulting from causes beyond its control. DuraTech Industries International Inc., shall **not** be held liable under this warranty for rental costs or any expense or loss for labor or supplies.

DuraTech Industries International Inc., reserves the right to make changes in material and/or designs of this product at any time without notice.

This warranty is void if DuraTech Industries International Inc. does not receive a valid warranty registration card at its office in Jamestown, North Dakota, USA, within 10 days from date of original purchase.

All other warranties made with respect to this product, either expressed or implied, are hereby disclaimed by DuraTech Industries International Inc.



Appendix B: Specifications

General

Length without hitch	23 ft.
Width with hopper extension	10 ft. 8 in.
Width without hopper extension	8 ft. 6 in.
Height	11 ft. 6 in.
Loading height	9 ft. 6 in.
Approximate weight	18,400 lbs.

Barrel

Length	16 ft.
Diameter	6 ft.
Shaft diameter	2-15/16 in.
Total screen area	275 sq. ft.

Feed system

Auger	12 in. dia. twin counter-rotating
Hopper with extension	3 cubic yards

Drive system

Engine (standard)	Isuzu 4JBI 70 hp.
Engine (optional)	Isuzu 56 hp. (Not compatible with side conveyor)
Hydraulic drive	Char-Lyn orbit motor coupled to 6:1 planetary gearbox
Final drive	100 Pitch heavy chain
Auger drive	80 Pitch heavy chain

Hydraulic drop legs Standard on all corners

Anti-blinding brushes 32-inch diameter nylon

Side apron Includes electric winch to assist folding

Hitch Choice of pintle, gooseneck or fifth wheel

Axle 15,000 lb. highway axle with electric brakes and leaf spring suspension

Options

- Slow-speed axle with flotation tires
- Side conveyor package
- Self-contained stacking conveyor (3 x 25 ft., 14-ft. stacking height)





Appendix C: Delivery Notification Form

To be filled out and returned to the factory upon delivery of any trommel screen unit.



IMPORTANT: No action, in terms of service or warranty, will be taken until this form, together with the "Verification of User Training Form" on the following page, are completed and returned to the factory.

Model of machine _____

Serial number of machine _____

Customer name _____

Dealer name _____

Address _____

Phone _____

Is owner a business? _____

Is owner a government entity? _____

Other? _____

What will be the primary application of this unit? _____

Engine type _____

Engine serial number _____

Date of sale of machine _____

Date of delivery of machine _____



IMPORTANT: All engine registration papers must be filed with the engine dealer in order to handle any future engine claims.



Appendix D: User Training Verification Form

We certify that the users of the Tromax 7216 trommel screen unit named below have read the instructions in the operating manual, and understand all information concerning the safe operation of the unit. We further certify that dealer personnel have provided instruction in the use of the unit, and have conducted a “walk-around” inspection of all safety instructional decals on the machine itself.

Signatures

User: _____ **Date:** _____

User: _____ **Date:** _____

User: _____ **Date:** _____

User: _____ **Date:** _____

Dealer: _____ **Date:** _____



IMPORTANT: This form, together with the “Delivery Notification Form” on the previous page, is to be completed and returned to the factory. No action, in terms of service or warranty, will be taken until this information is received by the factory.





Tromax 7216

Trommel Screening System

Part 2: Parts Reference

**BASE UNIT****6800208 Base Unit**

Part No.	Qty	Description
4800003	16	BOLT\HEX\3\8X1
4800013	4	BOLT\HEX\5\16X1
4800032	2	BOLT\HEX\5\8X5
4800034	6	BOLT\HEX\3\8X1-1/2
4800041	8	BOLT\HEX\1\2X5
4800053	12	BOLT\CRG\3\8X1\NC
4800098	33	BOLT\HEX\3\8X1-1/4\NC
4800106	4	BOLT\HEX\5\8X1-1/2
4800147	6	BOLT\HEX\5\16X7/8
4900002	45	NUT\HEX\3\8\NC
4900012	10	NUT\TPLCK\5\8\NC
4900023	6	NUT\TPLCK\3\8\NC
4900142	4	NUT\TPLCK\5\16
5000001	61	WASH\FLAT\3\8
5000004	16	WASH\FLAT\1\2
5000006	8	WASH\LOCK\1\2
5000019	61	WASH\LOCK\3\8
5000022	6	WASH\LOCK\5\16
5000023	10	WASH\FLAT\5\16
5000096	36	WASH\FLAT\SPCL\13\32X7GA>
5700213	1	SWITCH\BRKAWAY\12VDC>
6800004	1	FRM\MAIN\266X98X66\TROM
6800005	1	SH\STRPPR\66X64\REAR
6800006	1	SH\STRPPR\66X62-1/2\>
6800007	1	SH\STRPPR\66X67\FRONT
6800008	1	GUARD\BRRL\60X42-1/2\FRNT
6800009	1	GUARD\BRRL\55-1/2X42-1/2\
6800010	1	GUARD\BRRL\63X42-1/2\REAR
6800021	1	GUARD\DR\40X9-3\8X7\8>
6800023	1	GUARD\DISCH\33-1\8X15X>
6800046	1	SIDE LADDERS-TROMMEL
6800057	1	GUARD\CHN\15-1\2X10X1-1\4
6800058	2	GUARD\CHAIN\
6800063	2	GUARD\BRRL\22-1\2X15-1\2>
6800241	1	DOOR\DRIVE\53X15-3\4X7\8>
6800242	1	DOOR\ENGINE\32X23-3\4X>
6800243	1	CVR\BRNG\7216
6800244	1	SCRN\RAD\ISUZU\7216
7500166	2	LATCH\RBBR\6
7500190	2	LATCH\RBBR\CATCH\6
7500347	2	LATCH\RBBR\MNT\6
7500590	1	ENCL\OPS\8-1\2X11X1-5\8>



HOPPER EXTENSION OPTION

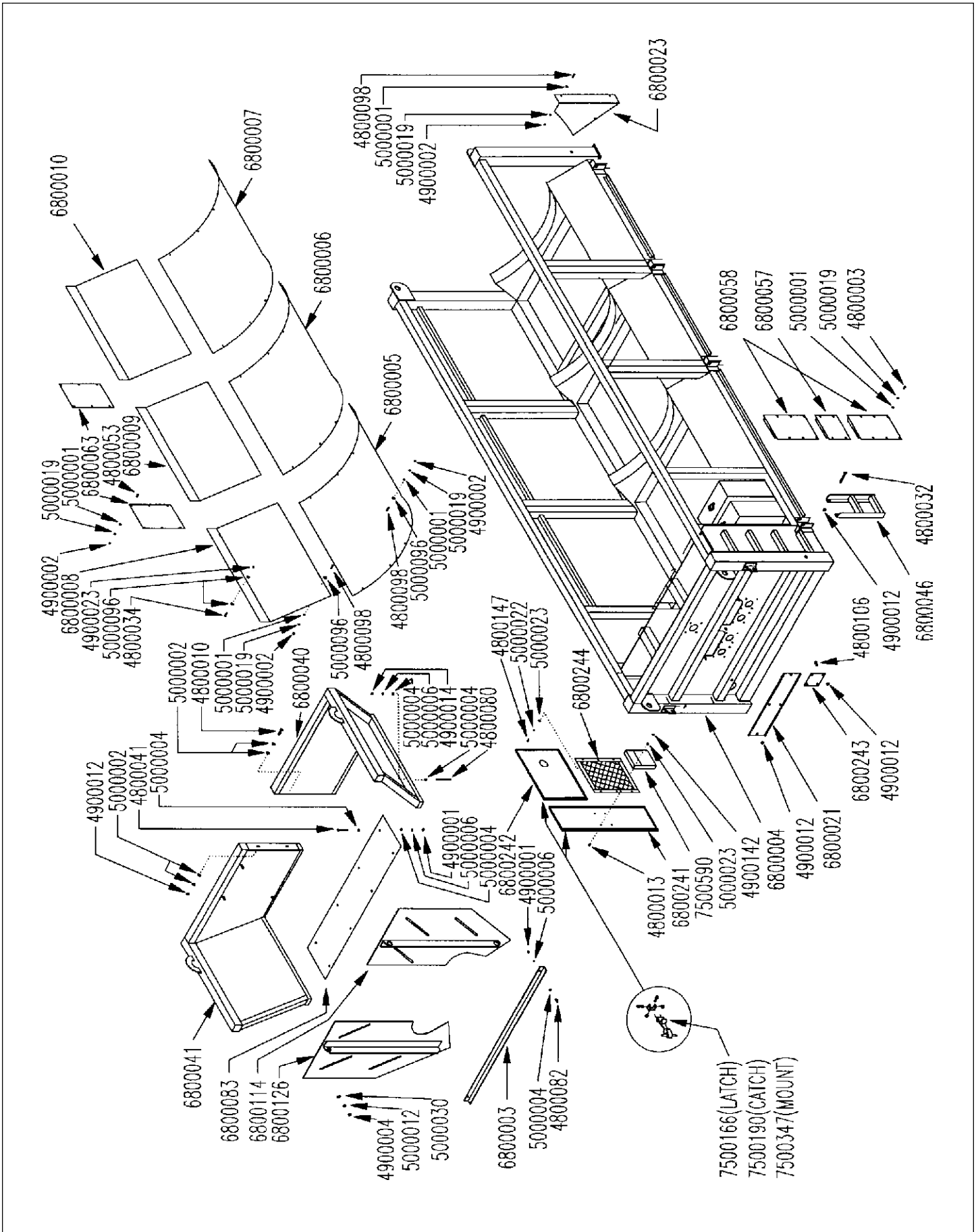



HOPPER EXTENSION OPTION

6800118 Hopper Extension Option

Part No.	Qty.	Description
6800118		HPPR\EXT\11'X4.5'X3\OPTN
4800010	2	BOLT\HEX\5/8X2
4800080	4	BOLT\HEX\1/2X7
4800082	2	BOLT\HEX\1/2X1-1/2
4900001	2	NUT\HEX\1/2\NC
4900012	2	NUT\TPLCK\5/8\NC
4900014	4	"NUT\TPLCK\1/2\NC\.500"MAX"
5000002	8	WASH\FLAT\5/8
5000004	10	WASH\FLAT\1/2
5000006	6	WASH\LOCK\1/2
6800003	1	ANGLE\HPPR\85X2-1/2X2-1/2
6800040	1	HPPR\EXT\63-7/8X56-1/4X>
6800041	1	HPPR\EXT\63-7/8X56-1/4X>

6800245 Adjustable Feed Control Plates

Part No.	Qty.	Description
6800245		KIT\PL\CNTRL\FEED\ADJ>
4900004	6	NUT\HEX\3/4\NC
5000030	12	WASH\FLAT\13/16\2"ODX1/4T
5000012	6	WASH\LOCK\3/4
6800114	1	DOOR\HPPR\RH\72X36X4\>
6800126	1	DOOR\HPPR\LH\72X36X4\>



BRUSH ASSEMBLY

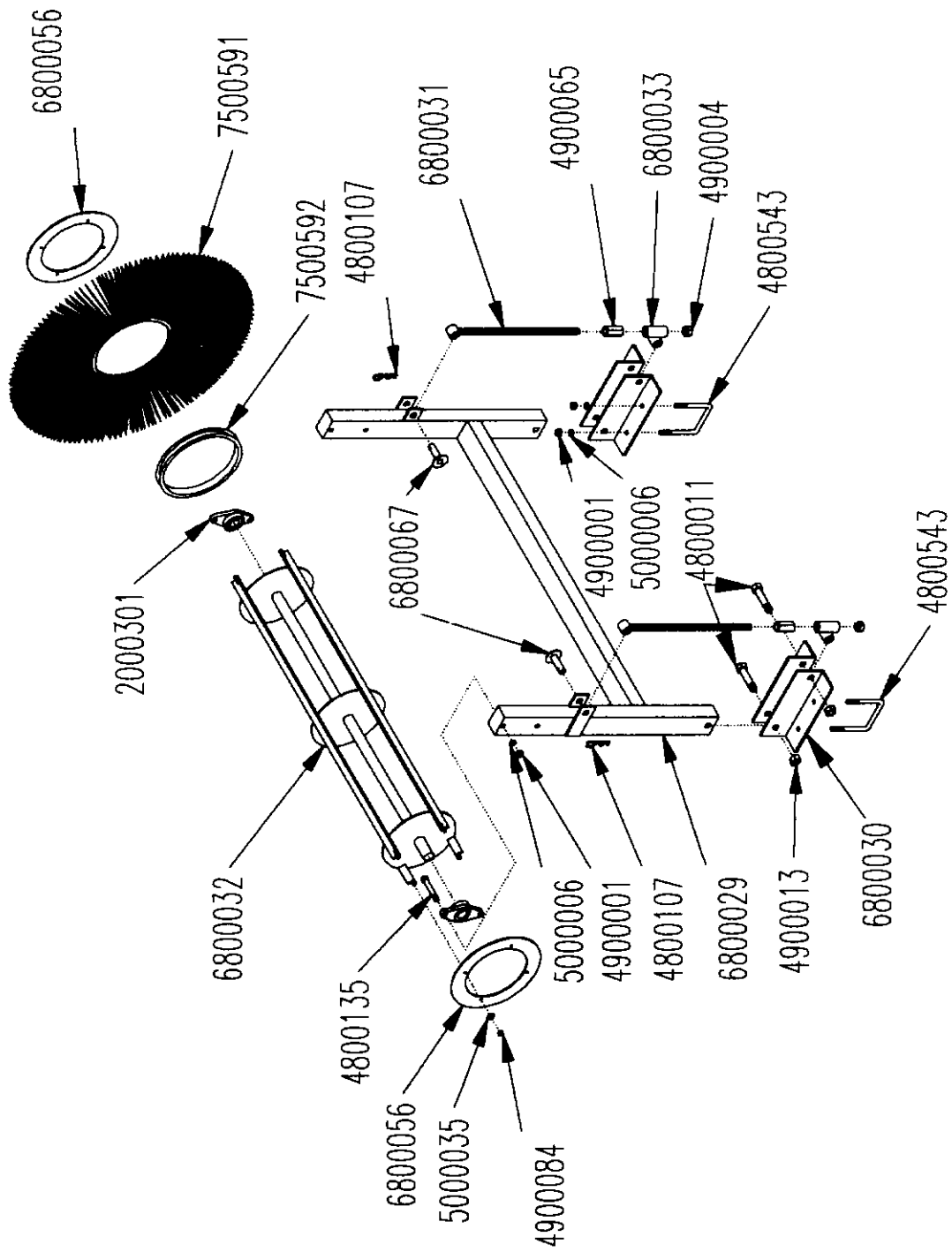



BRUSH ASSEMBLY

6800212 Brush Assembly

Part No.	Qty.	Description
2000301	2	BRG\FLG\CAST\1-1/4\2BOLT
4800011	4	BOLT\HEX\3/4X3-1/2
4800107	2	PIN\HAIR\1/8 (#9)
4800135	4	BOLT\HEX\1/2X3-1/2
4800543	4	BOLT\U\1/2X4-1/8X5\PLTD
4900001	12	NUT\HEX\1/2\NC
4900004	2	NUT\HEX\3/4\NC
4900013	4	NUT\TPLCK\3/4\NC
4900065	2	NUT\CPLG\3/4\NC
4900084	8	NUT\TPLCK\1/4\NC
5000006	12	WASH\LOCK\1/2
5000035	8	WASH\FLAT\1/4
6800029	1	FRM\BRUSH\53-1/2X32X>
6800030	2	BRKT\BRUSH\11X8-1/4X5\>
6800031	2	BOLT\ADJ\3/4X19-1/4\W\>
6800032	1	FRM\BRUSH\48-1/2X10D\>
6800033	2	SWVL\BRUSH\3X1-7/8X2-1/2>
6800056	2	FLG\BRUSH\12DX8-1/4IDX1/8
6800067	2	PIN\BRUSH\2-3/4X1D\W\WASH
7500591	13	BRUSH\RD\32DX5/8X10-1/8\>
7500592	34	SPCR\BRUSH\11DX1-1/8X>

NOTE: There are 3 brush assemblies per machine.



BARREL ASSEMBLY

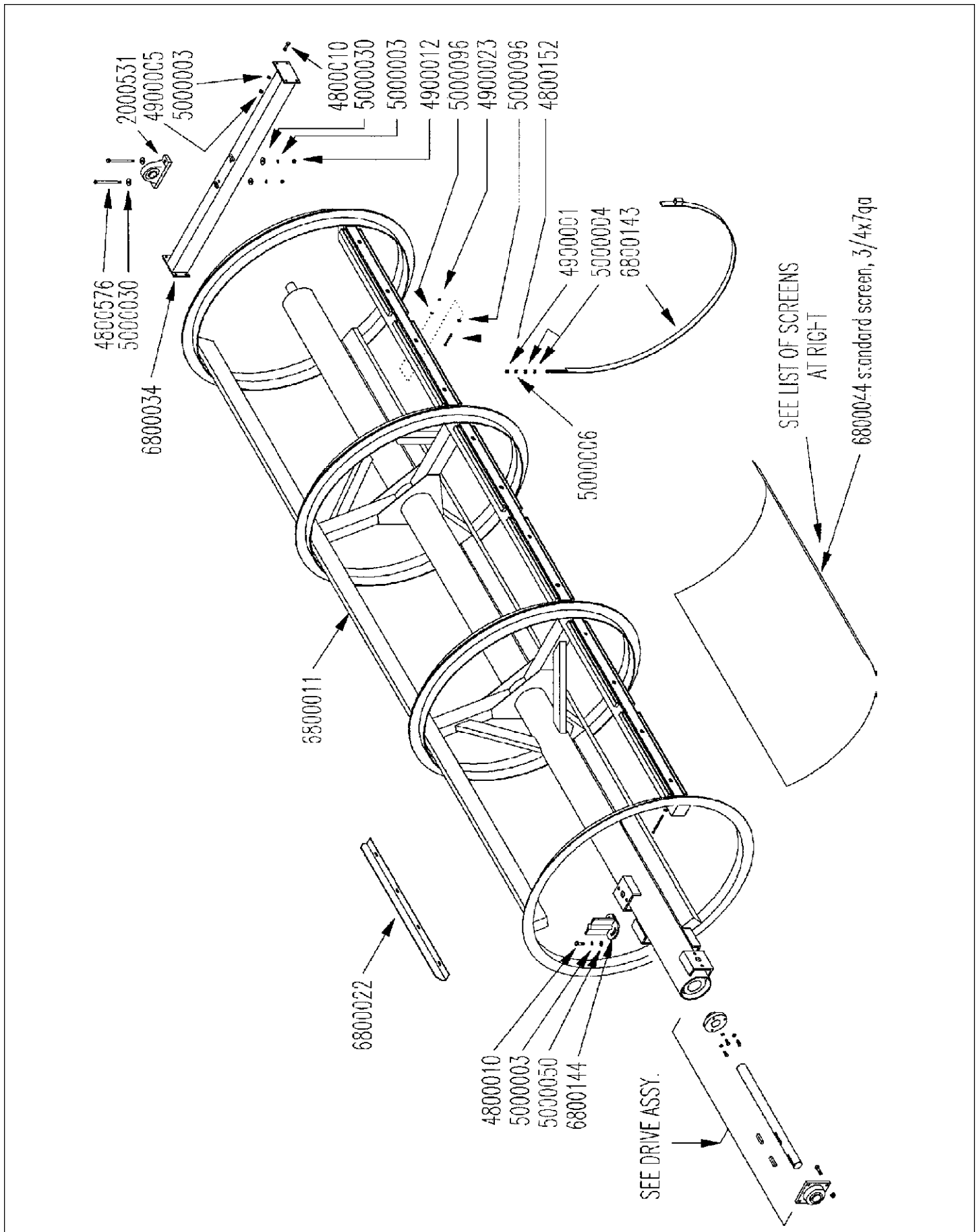



BARREL ASSEMBLY

6800235 Barrel Assembly

Part No.	Qty.	Description
2000531	1	BRG\PB\2-15/16\2BOLT\SCM
4800010	8	BOLT\HEX\5/8X2
4800152	72	BOLT\HEX\3/8X4-1/2
4800576	2	BOLT\HEX\5/8X9
4900001	12	NUT\HEX\1/2\NC
4900005	8	NUT\HEX\5/8\NC
4900012	2	NUT\TPLCK\5/8\NC
4900023	72	NUT\TPLCK\3/8\NC
5000003	10	WASH\LOCK\5/8
5000004	24	WASH\FLAT\1/2
5000030	4	WASH\2"ODX3/4IDX1/4THICK"
5000096	144	WASH\FLAT\SPCL\13/32X7GA>
6800011	1	FRM\BRRL\192X76\TROM
6800022	9	ANGLE\STRPPR\60X2-5/8X>
6800034	1	FRM\BRRL\85-1/4X9X6\>
6800143	12	SCRN\CLMP\72DX1-1/2\7216

Select screens, (total of 9 required for machine, 3 per bay)

6800129		SCRN\WIRE\62-1/2X36R\1/4X0.120"
6800050		SCRN\WIRE\62-1/2X36R\3/8x#9
6800049		SCRN\WIRE\62-1/2X36R\1/2x#7
6800044		SCRN\WIRE\3/4X7GA\63X82\>
6800048		SCRN\WIRE\62-1/2X36R\1x#3
6800047		SCRN\WIRE\62-1/2X36R\1-1/2x3/8>
6800132		SCRN\WIRE\62-1/2X36R\2x5/16

6800236 Paddle Option

Part No.	Qty.	Description
6800236		AGGTR\PDDL\7216\OPTN
4800010	8	BOLT\HEX\5/8X2
5000050	8	WASH\FLAT\11/16\2"ODX1/4T



DRIVE ASSEMBLY

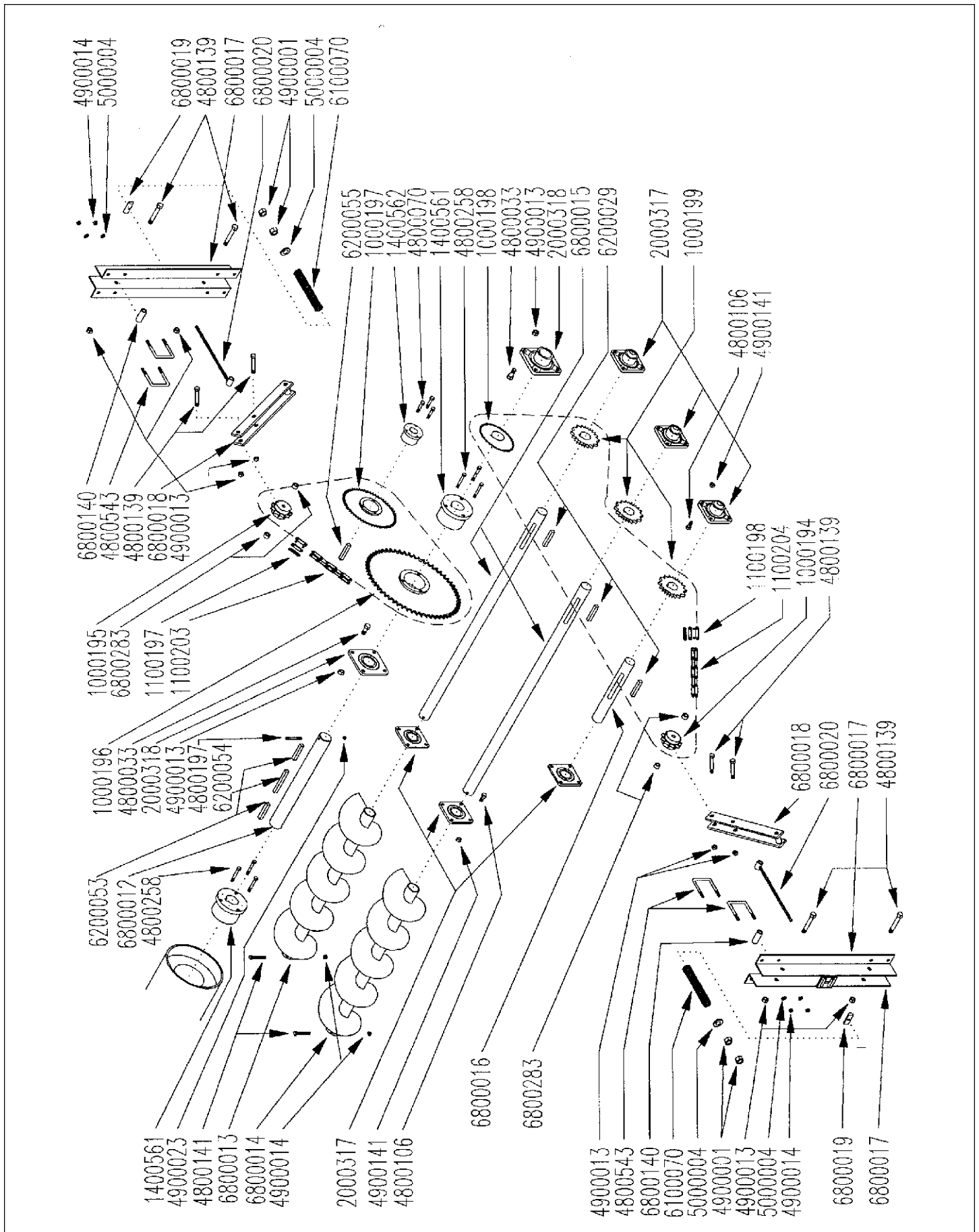

**DRIVE ASSEMBLY****6800237 Drive Assembly**

Part No.	Qty.	Description
1000194	1	SPKT\80\12\3/4\IDLER
1000195	1	SPKT\100\11\3/4\IDLER
1000196	1	SPKT\100\QD\54\J-BUSH
1000197	1	SPKT\100\QD\30\E-BUSH
1000198	1	SPKT\80\B\26\2-15/16\3/4>
1000199	3	SPKT\80\B\20\2-7/16\5/8>
1100197	1	CHAIN\100\DIAMND\CL
1100198	1	CHAIN\80\DIAMND\CL
1100203	1	CHAIN\100\DIAMND\107LINKS
1100204	1	CHAIN\80\DIAMND\99LINKS
1400561	2	BUSH\QD\J\2-15/16
1400562	1	BUSH\QD\E\2-3/4
2000317	6	BRG\FLG\2-7/16\4BOLT\SCM
2000318	2	BRG\FLG\2-15/16\4BOLT\SCM
4800033	8	BOLT\HEX\3/4X2
4800070	3	BOLT\HEX\1/2X2-1/2
4800106	24	BOLT\HEX\5/8X1-1/2
4800139	8	BOLT\HEX\3/4X4-1/2
4800141	2	BOLT\HEX\1/2X4-1/2
4800197	1	BOLT\HEX\3/8X3-1/2
4800258	6	BOLT\HEX\9/16X3-1/2
4800543	8	BOLT\U\1/2X4-1/8X5\PLTD
4900001	4	NUT\HEX\1/2\NC
4900013	16	NUT\TPLCK\3/4\NC
4900014	18	NUT\TPLCK\1/2\NC\.500" MAX
4900023	1	NUT\TPLCK\3/8\NC
4900141	24	NUT\HEX\5/8\TOPLOCK\GR8
5000004	18	WASH\FLAT\1/2
6100070	2	SPRNG\COMP\1-1/8\.162\7"
6200029	3	KEY\SQ\5/8X2
6200053	2	KEY\SQ\3/4X2-1/4
6200054	1	KEY\SQ\3/4X4-1/2
6200055	1	KEY\STEP\5/8X3/4X3
6800012	1	SHFT\BRRL\72X2-15/16\W>
6800013	1	CNVYR\SCR\43-3/8X12\LH\>
6800014	1	CNVYR\SCR\43-3/8X12\RH\>
6800015	2	SHFT\SCR\65-1/2X2-7/16\D>
6800016	1	SHFT\CNTR\18-1/2X2-7/16>
6800017	2	BRKT\DR\37X7X4-3\TGHTNR>
6800018	2	BRKT\IDLER\20-1/2X2-1/2>
6800019	2	SWVL\DRV\3X1-1/4X5/8\>
6800020	2	BOLT\ADJ\1/2X18-1/4\W>
6800140	2	BUSH\SPCR\3-1/8C1-1/4\ODX>
6800283	4	BUSH\SPCR\3/4X1-1/2\ODX3/4\ID



ELECTRIC HIGHWAY AXLE

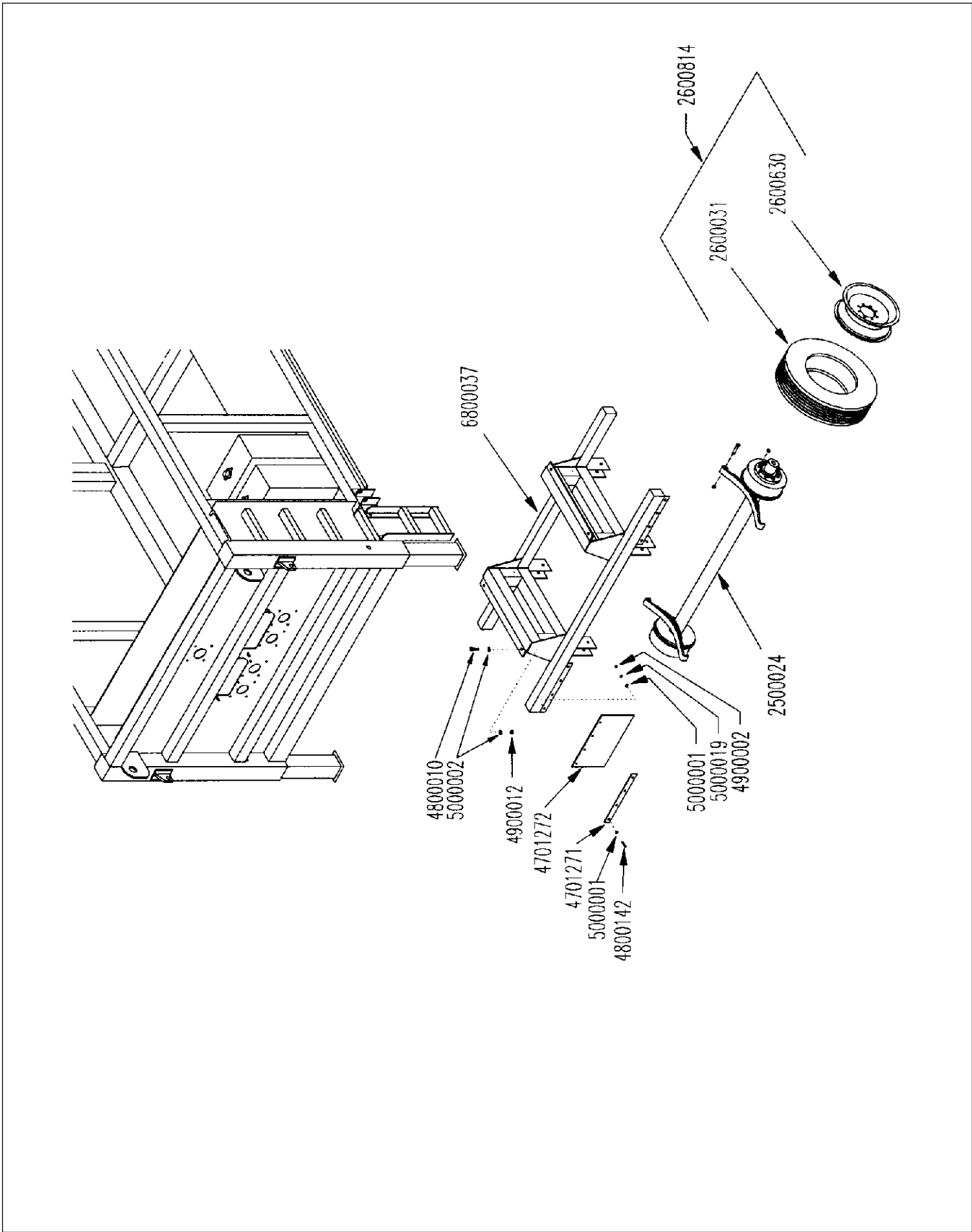



ELECTRIC HIGHWAY AXLE

6800209 Electric Highway Axle

Part No.	Qty.	Description
2500024	1	AXLE\COMP\15K\ELEC
2500903	1	MNT\SUSP\HAP103\KIT\>
2600814	4	WHEEL\ASSY\215X75RX17.5\>
2600031	4	TIRE\HWY\215/75RX17.5
2600630	4	17.5X6.75 HC DUAL
4701271	2	FLAT\DBLR\21X2X3/16\MUD>
4701272	2	GUARD\TIRE\22-1/2X12X1/4\
4800010	4	BOLT\HEX\5/8X2
4800142	8	BOLT\HEX\3/8X1-3/4
4900002	8	NUT\HEX\3/8\NC
4900012	4	NUT\TPLCK\5/8\NC
5000001	16	WASH\FLAT\3/8
5000002	8	WASH\FLAT\5/8
5000019	8	WASH\LOCK\3/8
5700010	1	TERM\MALE\7POLE\TRCK\PLUG
5700011	1	TERM\FEMALE\7POLE\TRLR\>
5700033	1	TERM\MALE\6POLE\TRLR\PLUG
5700034	1	ENCL\JCT\7POLE\TRLR\HARN
5700038	2	LAMP\CL\12VDC\AMBER
5700192	4	LAMP\RFLCTR\AMB\4-3/8X>
5700193	2	LAMP\RFLCTR\RED\4-3/8X>
5700201	4	LAMP\TAIL\4-1/2\COMP\RED>
5700202	3	LAMP\GRMMT\2-1/2\KIT\>
5700210	1	TERM\CONN\2POLE\MOLDED\>
5700213	2	SWITCH\BRKAWAY\12VDC\>
6800037	1	FRMAXLE\94X36-3/4X>



SLOW-SPEED AXLE OPTION

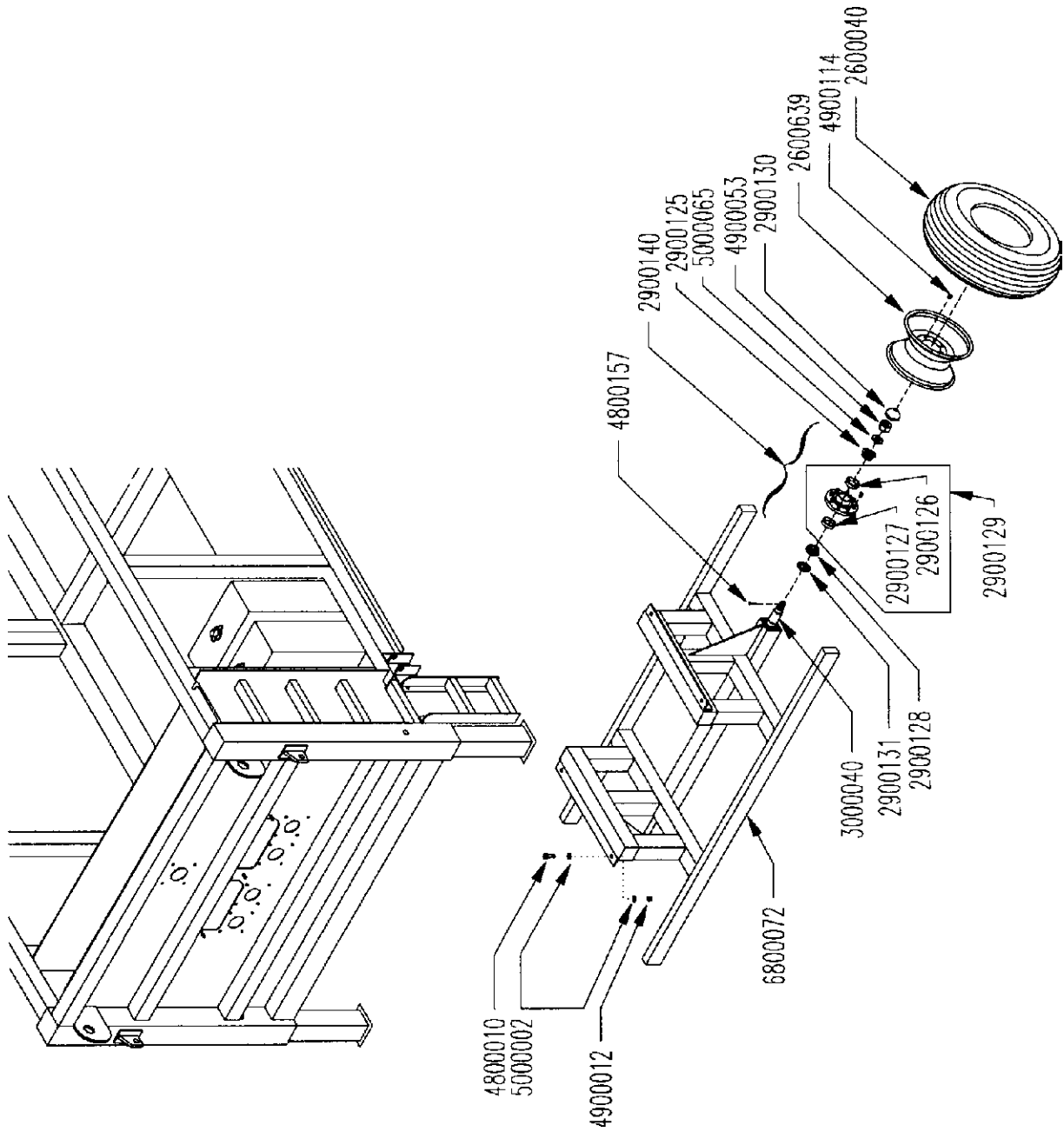



SLOW-SPEED AXLE OPTION

6800122 Slow-Speed Axle Option

Part No.	Qty.	Description
2600040	2	TIRE\16.5X16.1SL\10PLY
2600639	2	WHL\8BOLT\16.1X14\>
2900140		HUB\8BOLT\COMP\>
2900125	2	OUTER CONE H817 HUB
2900128	2	INNER CONE H817 HUB
2900129	2	HUB\8BOLT\W/RACES\W/NUTS\>
2900126		OUTER CUP H817 HUB
2900127		INNER CUP H817 HUB
4900114		NUT\TPR\WHEEL\5/8\NF
2900130	2	DUST CAP H817
2900131	2	GREASE SEAL H 817
3000040	2	SPNDL\HUB\3\H817\16\TROM
4800010	4	BOLT\HEX\5/8X2
4800157	2	PIN\COT\3/16X2
4900012	4	NUT\TPLCK\5/8\NC
4900053	2	NUT\CASTLE\1-1/4\NF
5000002	8	WASH\FLAT\5/8
5000065	2	2.5 ODX 1.25ID 224 WASH
6800072	1	FRMAXLE\SLOW\101X48X25



PINTLE HITCH

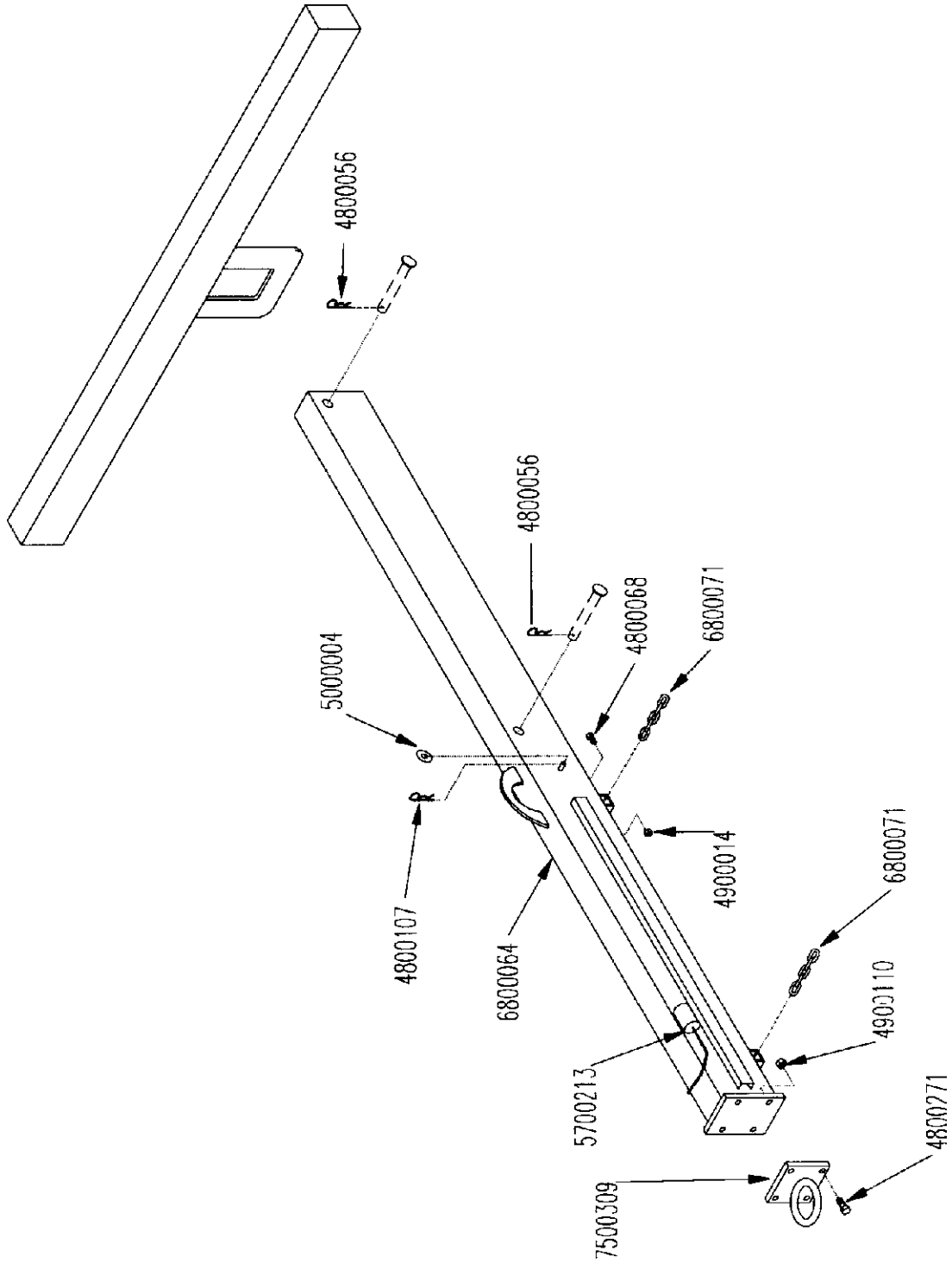



PINTLE HITCH

6800123 Pintle Hitch

Part No.	Qty.	Description
4800056	2	PIN\HAIR\3\16X3 (#6)
4800068	2	BOLT\HEX\1\2X3
4800271	4	BOLT\HEX\5\8X2-1\2\GR8
4900014	2	NUT\TPLCK\1\2\NC\.500"MAX"
4900110	4	NUT\FLG\SERR\5\8\NC
5700213	1	SWITCH\BRKAWAY\12VDC\>
6800064	1	FRM\HITCH \PINTLE
6800071	2	CHAIN\HITCH\40X3\8\TROM
7500309	1	DRAW BAR HITCH 4 BOLT



GOOSENECK HITCH OPTION

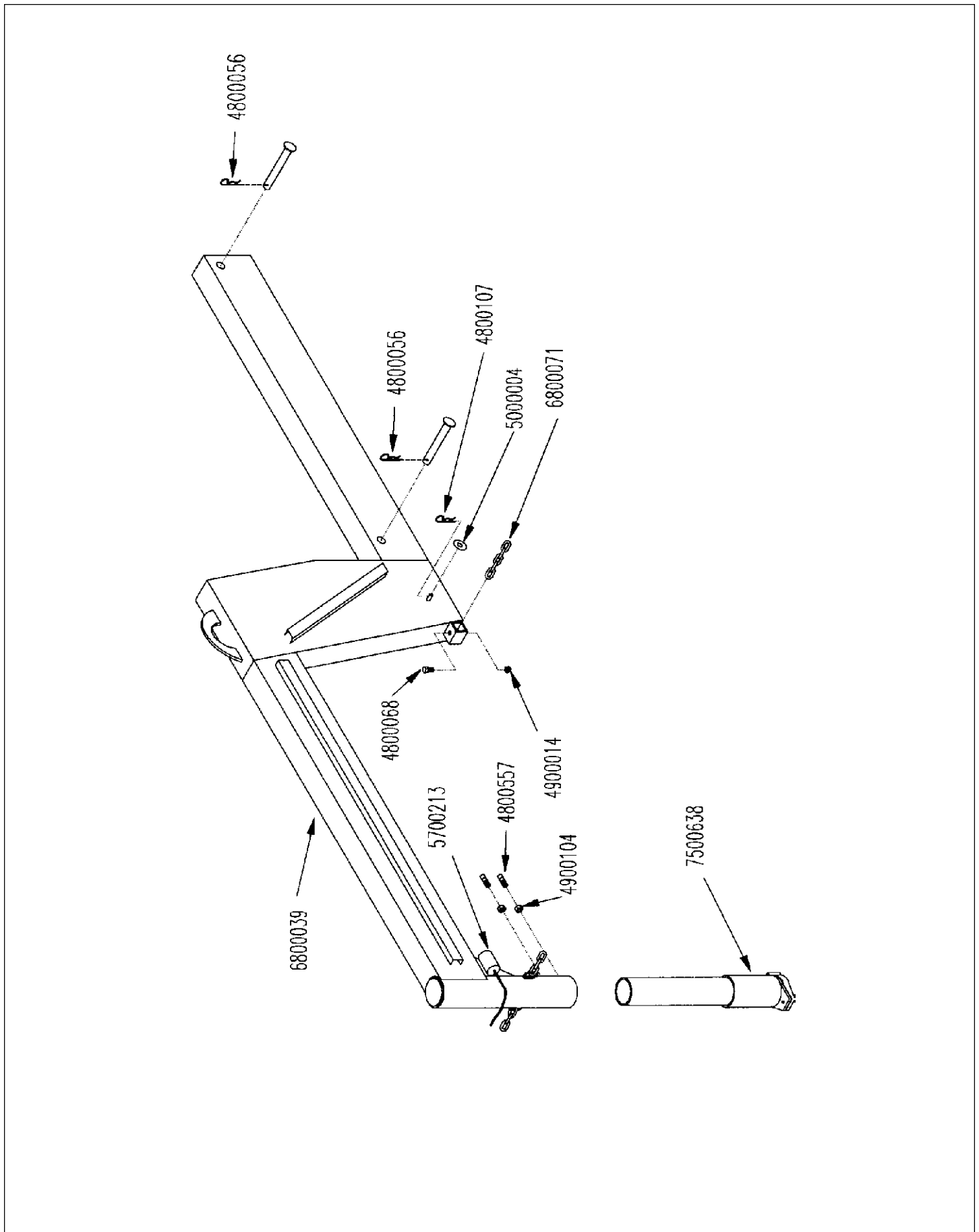



GOOSENECK HITCH OPTION

6800124 Gooseneck Hitch Option

Part No.	Qty.	Description
4800056	2	PIN\HAIR\3/16X3 (#6)
4800068	1	BOLT\HEX\1/2X3
4800107	1	PIN\HAIR\1/8 (#9)
4800557	2	SCR\SET\SQ\3/4X2\NC
4900014	1	"NUT\TPLCK\1/2\NC\.500"MAX"
4900104	2	NUT\JAM\3/4\NC
5000004	1	WASH\FLAT\1/2
5700213	1	SWITCH\BRKAWAY\12VDC\>
6800039	1	FRM\HITCH\153X44X4-1/2>
6800071	1	CHAIN\HITCH\40X3/8\TROM
7500638	1	CPLG\HITCH\2-5/16\RD\>



FIFTH WHEEL HITCH OPTION

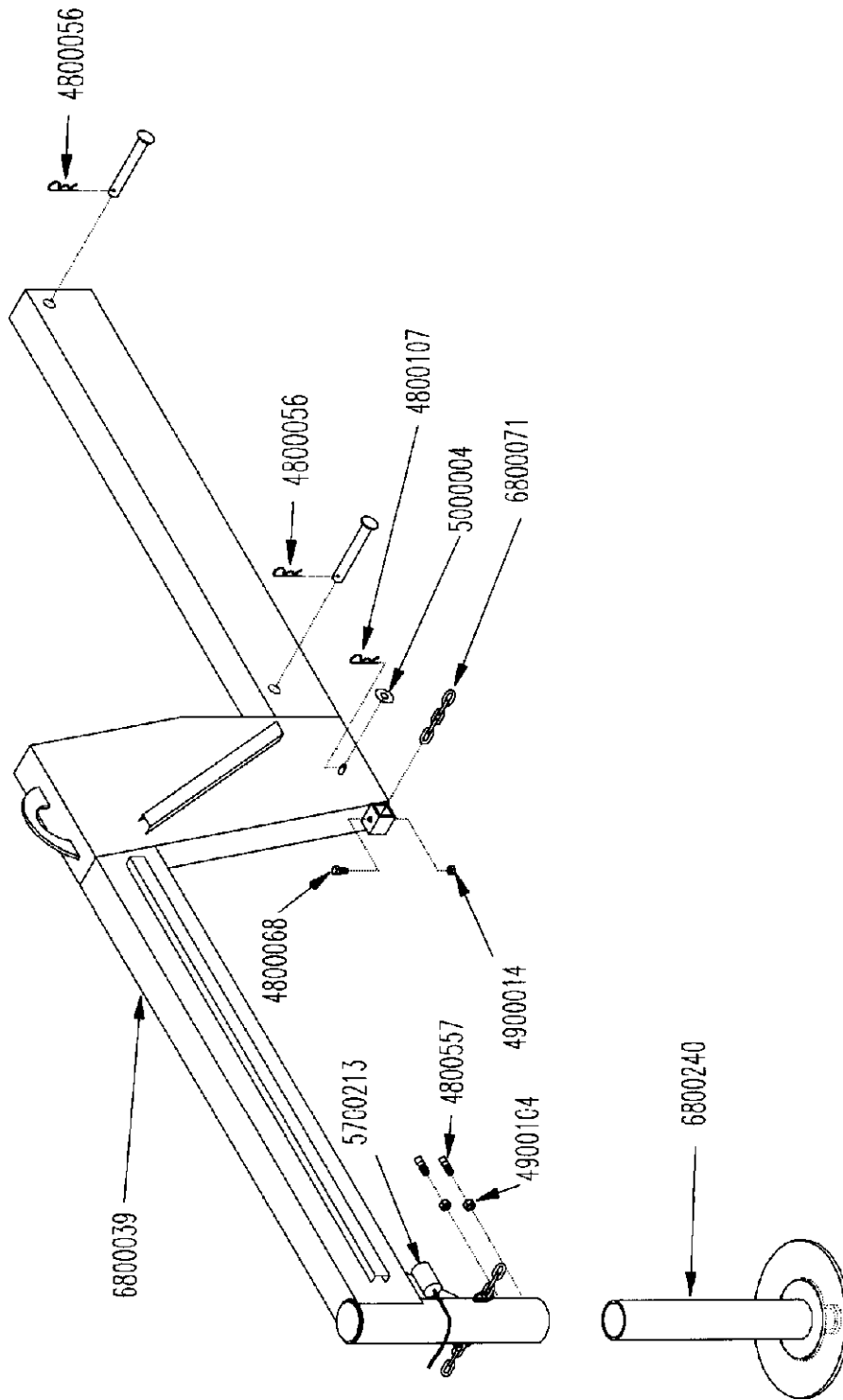



FIFTH WHEEL HITCH OPTION

6800125 Fifth Wheel Hitch Option

Part No.	Qty.	Description
4800056	2	PIN\HAIR\3\16X3 (#6)
4800068	1	BOLT\HEX\1\2X3
4800107	1	PIN\HAIR\1\8 (#9)
4800557	2	SCR\SET\SQ\3\4X2\NC
4900014	1	"NUT\TPLCK\1\2\NC\.500"MAX"
4900104	2	NUT\JAM\3\4\NC
5000004	1	WASH\FLAT\1\2
5700213	1	SWITCH\BRKAWAY\12VDC\>
6800039	1	FRM\HITCH\153X44X4-1\2>
6800071	1	CHAIN\HITCH\40X3\8\TROM
6800240	1	PIN\WHL\FIFTH\ADAPTER

**SIDE APRON****6800210 Side Apron**

Part No.	Qty.	Description
1400082	1	SHVE\CBL\W\BRG
4800050	5	PIN\COT\3\16X1-1\2
4800079	1	BOLT\HEX\5\8X2-1\2
4800158	5	BOLT\HEX\5\8X4-1\2
4800543	2	BOLT\U\1\2X4-1\8X5\PLTD
4800561	14	SCR\SD&T\1\4X1
4900001	2	NUT\HEX\1\2\INC
4900012	6	NUT\TPLCK\5\8\INC
4900014	4	"NUT\TPLCK\1\2\INC\.500"MAX"
5000004	6	WASH\FLAT\1\2
5000005	1	WASH\FLAT\3\4
5000006	2	WASH\LOCK\1\2
5700229	1	SWITCH\WINCH\ID&L\206007
5800016	1	12 VOLT WINCH SA9005
6800026	1	FRM\APRON\234X46X3-1\8>
6800027	1	BRKT\APRON\97X3SQ\STRUT\
6800028	1	BRKT\APRON\95-7\8SQ>
6800052	1	BRKT\WINCH\
6800053	1	BRKT\FORK\
6800060	3	BRKT\WIRE\54X2-1\4X2\WCH
6800061	1	BRKT\WIRE\28X2-1\4X2\WCH
6800070	1	GUIDE\CABLE\2-1\2X1-1\2X>
6800142	1	PIN\LIFT\3\4X7\APRON



SIDE CONVEYOR ASSEMBLY

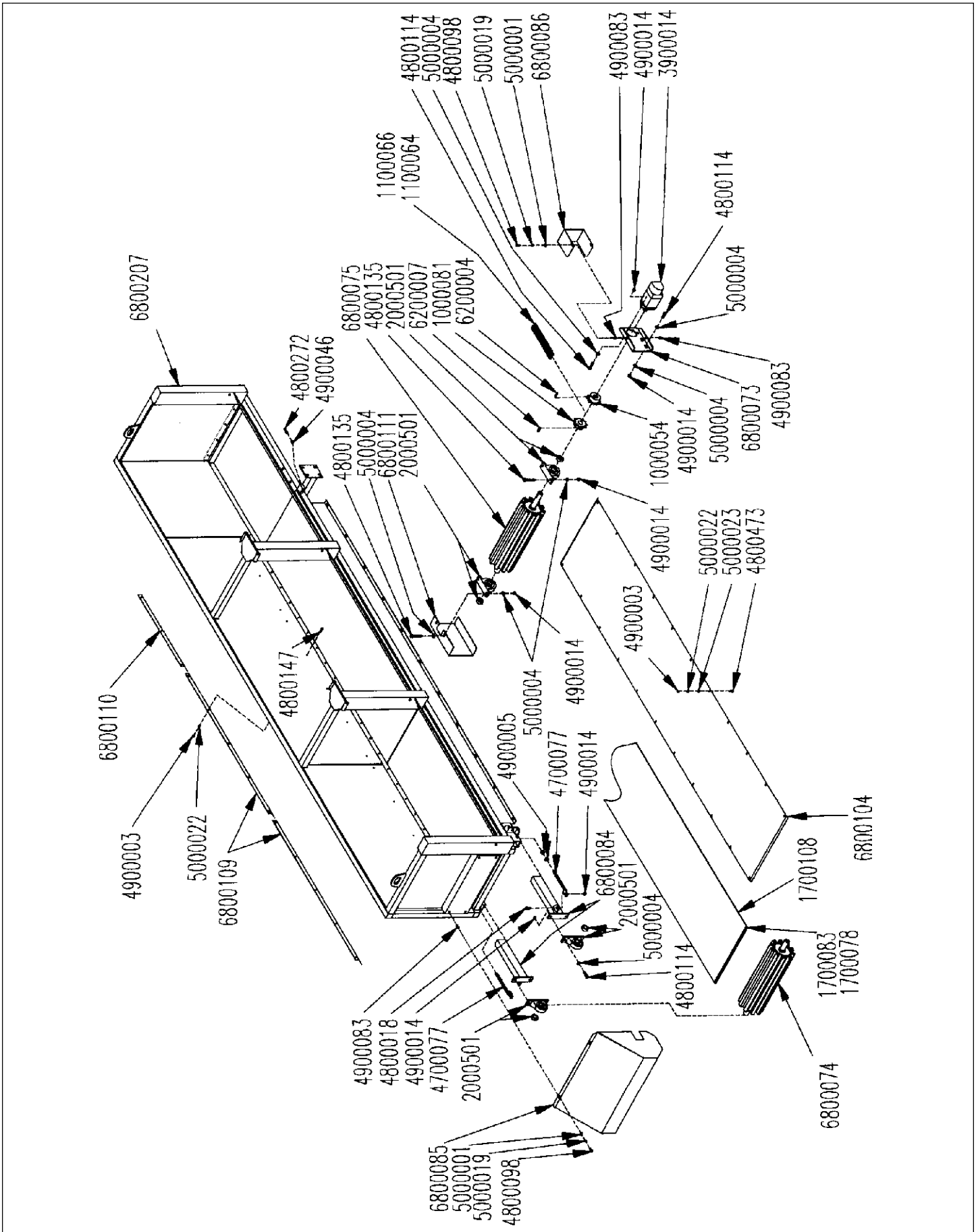

**SIDE CONVEYOR ASSEMBLY****6800202 Side Conveyor Assembly**

Part No.	Qty.	Description
1000054	1	SPKT\60\18\1-1/4\5/16KW
1000081	1	SPKT\60\18\1-1/2\3/8KW
1100064	1	CHAIN\60DBL\CL
1100066	1	CHAIN\60DBL\17
1700078	1	LCNG\CBL\1/8X24
1700083	1	LCNG\#125\24\W\STPLS
1700108	1	BELT\CNVYR\24X355\FS
2000501	4	BRG\PB\1-1/2\2BOLT
3900014	1	MTR\HYD\9.6\2000\1-1/4SH
4700077	2	BOLT\CNVYR\TENSION ADJ
4800018	2	BOLT\HEX\1/2X1-1/4
4800098	6	BOLT\HEX\3/8X1-1/4\NC
4800114	10	BOLT\HEX\1/2X2
4800135	4	BOLT\HEX\1/2X3-1/2
4800147	13	BOLT\HEX\5/16X7/8
4800272	2	SCR\SET\ALN\1/2X2\NC
4800473	22	BOLT\CRG\5/16X1\NC
4900003	35	NUT\HEX\5/16\NC
4900005	4	NUT\HEX\5/8\NC
4900014	16	"NUT\TPLCK\1/2\NC
4900046	2	NUT\JAM\1/2\NC
4900083	6	NUT\INSRT\3/8\LONG\>
5000001	6	WASH\FLAT\3/8
5000004	20	WASH\FLAT\1/2
5000019	6	WASH\LOCK\3/8
5000022	35	WASH\LOCK\5/16
5000023	22	WASH\FLAT\5/16
6200004	1	KEY\SQ\5/16X1-1/2
6200007	1	KEY\SQ\3/8X1-1/2
6800073	1	MNT\MOT\10-1/8X6-1/2X>
6800074	1	RLLR\IDLER\31X8\CNVYR
6800075	1	RLLR\DRIVE\32X8\CNVYR
6800084	2	BRKT\RLLR\16-3/8X7X4-1/2>
6800085	1	GUARD\RLLR\32X21-1/4X>
6800086	1	GUARD\CPLG\7X7X5\CNVYR
6800104	1	GUARD\BELT\138X37\SIDE\>
6800109	2	GUARD\BELT\60X4\SIDE\CNVR
6800110	1	GUARD\BELT\31X4\SIDE\CNVR
6800111	1	GUARD\RLLR\13-1/2X9X3-1/2
6800207	1	FRAME\MAIN\CNVYR\SIDE\>



SIDE CONVEYOR SEAL ASSEMBLY

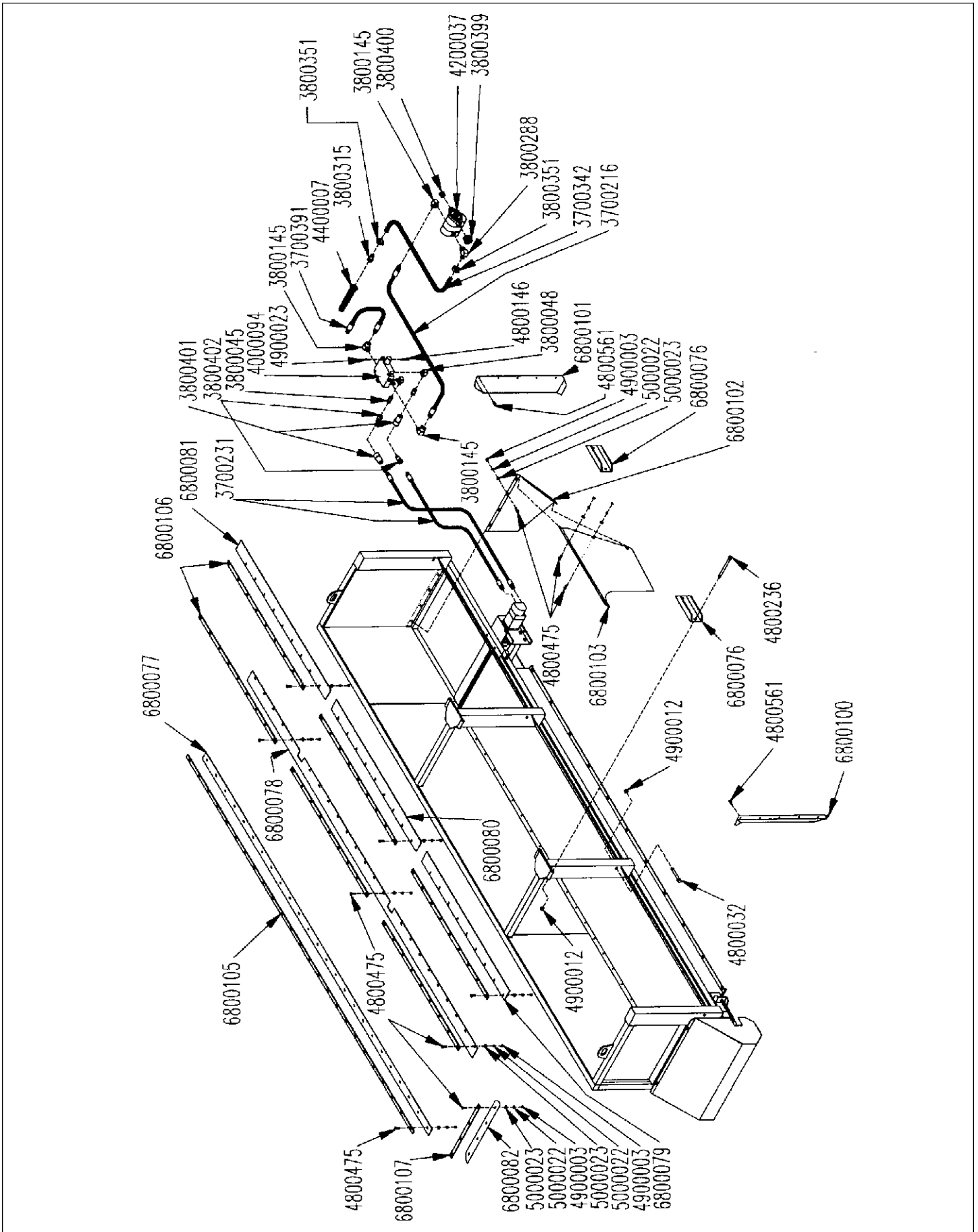

**SIDE CONVEYOR SEAL ASSEMBLY****6800203 Side Conveyor Seal Assembly**

Also Contains Hydraulic, Shipping assembly.

Part No.	Qty.	Description
3700231	2	HOSE\HYD\1\2X82\SWORING
3800401	1	FTG\1\2FP\CPLG\F\PIONEER
3800402	1	FTG\1\2FP\CPLG\M\PIONEER
4800475	79	BOLT\CRG\5\16X1-1\2\NC
4900003	79	NUT\HEX\5\16\NC
5000022	79	WASH\LOCK\5\16
5000023	79	WASH\FLAT\5\16
6800077	1	SEAL\BELT\160X2-3\4X1\8\>
6800078	1	SEAL\BELT\160X4X1\8\>
6800079	1	SEAL\FRAME\59X4X1\8\>
6800080	1	SEAL\FRAME\60-1\2X4X1\8\>
6800081	1	SEAL\FRAME\63-3\4X4X1\8\>
6800082	1	SEAL\BELT\24-3\4X2-3\4X\>
6800105	1	STRIP\SEAL\160X1X3-16
6800106	6	STRIP\SEAL\54X1-1\4X3-16
6800107	1	STRIP\SEAL\21-1\2X1-1\4X\>
6800205		CNVYR\SIDEKIT\HYD\7216
3700216	1	HOSE\HYD\3\4X67\SW-SW
3700342	3	HOSE\SCTN\1-1\4\20C4
3700391	1	HOSE\HYD\3\4X50\3\4MPSX\>
3800045	2	FTG\1\2MPX2\NPL
3800048	2	FTG\3\4MORX1\2FP\90D\ST;\>
3800145	3	FTG\1-1\16MORX3\4FP\90D\>
3800288	1	FTG\1-5\8MORX1-1\4BARB\>
3800315	1	FTG\1-1\4MPX1-1\4BARB\>
3800351	2	CLAMP\HOSE\1-3\4\T-BOLT\>
3800399	1	FTG\1-7\8MORX1-5\8FOR\>
3800400	1	FTG\1-5\8MORX1-1\16FOR\>
3800401	1	FTG\1\2FP\CPLG\F\PIONEER
3800402	1	FTG\1\2FP\CPLG\M\PIONEER
4000094	1	VALVE\HYD\1-SPL\FLO;CNTRL
4200037	1	PUMP\HYD\30\11\TNDM\COMM\>
4400007	1	FLTR\SCRN\2MPX1-1\4FP\25\>
4800146	3	BOLT\HEX\3\8X2
4900023	3	NUT\TPLCK\3\8\NC
6800206		CNVYR\SIDEKIT\SHIP\7216
4800032	4	BOLT\HEX\5\8X5
4800236	4	BOLT\HEX\5\8X8
4800475	11	BOLT\CRG\5\16X1-1\2\NC
4800477	10	BOLT\CRG\3\8X1-1\2\NC
4800561	10	SCR\SD&T\1\4X1
4900003	11	NUT\HEX\5\16\NC
4900012	8	NUT\TPLCK\5\8\NC
5000022	11	WASH\LOCK\5\16
5000023	11	WASH\FLAT\5\16
6800076	2	BRKT\CNVYR\SIDE\11X4\MNT
6800100	1	GUIDE\CNVYR\34-1\2X7\>
6800101	1	GUIDE\CNVYR\34-1\2X7\>
6800102	1	GUIDE\CNVYR\SIDE\DISCH\>
6800103	1	GUIDE\CNVYR\SIDE\DISCH\>



REAR DROP LEG

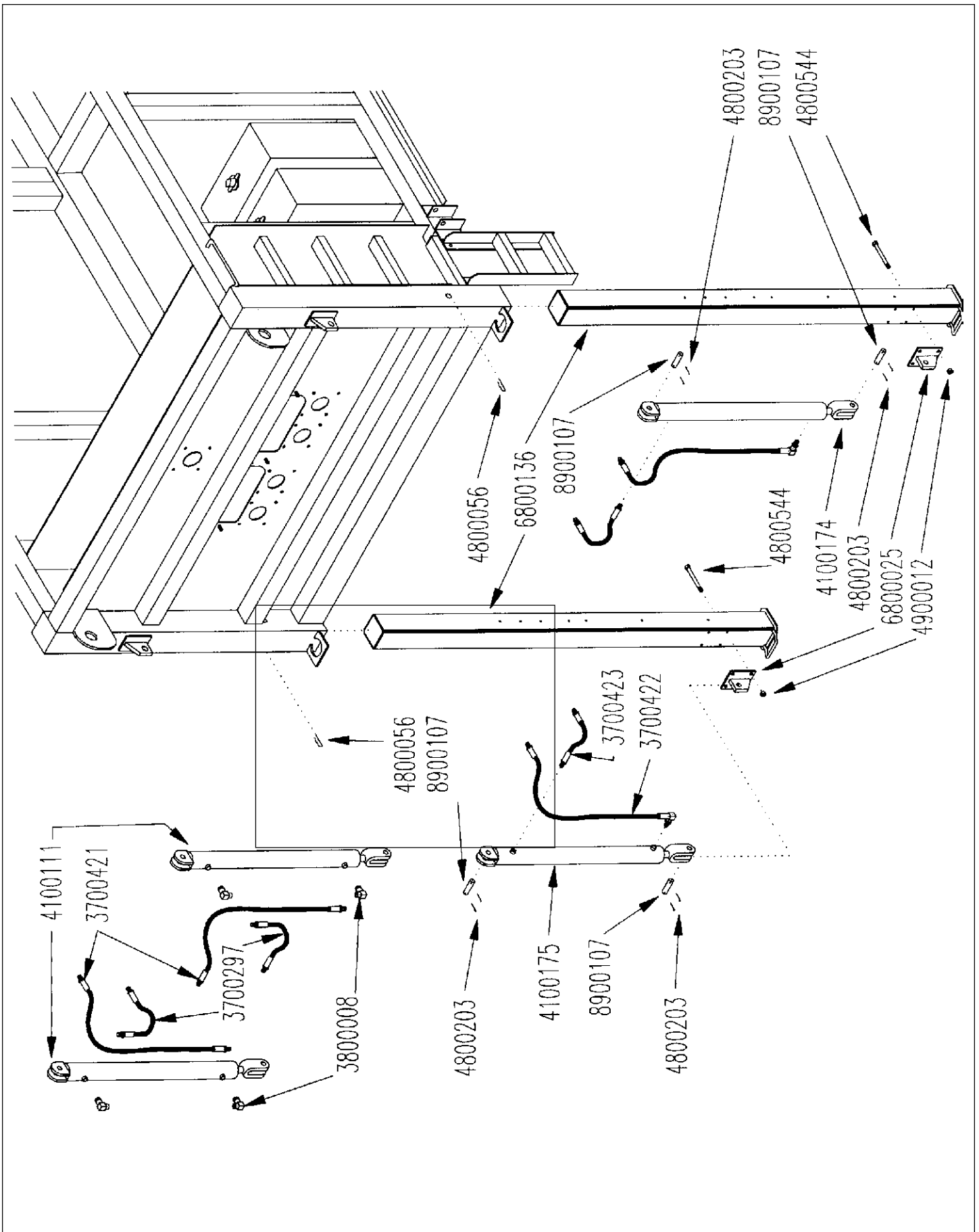



REAR DROP LEG

6800116 Rear Drop Leg

Part No.	Qty.	Description
4800056	2	PIN\HAIR\3\16X3 (#6)
4800203	8	PIN\COT\5\32X2
4800544	8	BOLT\HEX\5\8X6\NC
4900012	8	NUT\TPLCK\5\8\NC
6800025	2	BRKT\CYL\6X5X3-3\8\DROP>
6800136	2	LEG\HYD\96-1\4X5-3\8X>
8900107	4	1"X3 5\8" PIN
3700297	2	HOSE\HYD\1\2X19\SW-S0
3700421	2	HOSE\HYD\1\2X39\SW-S0
3800008	4	FTG\1\2MPX1\2FP\90D\ST;EL
4100111	1	CYL\HYD\3X36\PERP
3700422	2	HOSE\HYD\1\2X39\7\8MORS90X1\2MPS
3700423	2	HOSE\HYD\1\2X18\7\8MORSXX1\2MP
4100175	2	CYL\HYD\3X36\PARALLEL\



REAR DROP LEG CONTROL

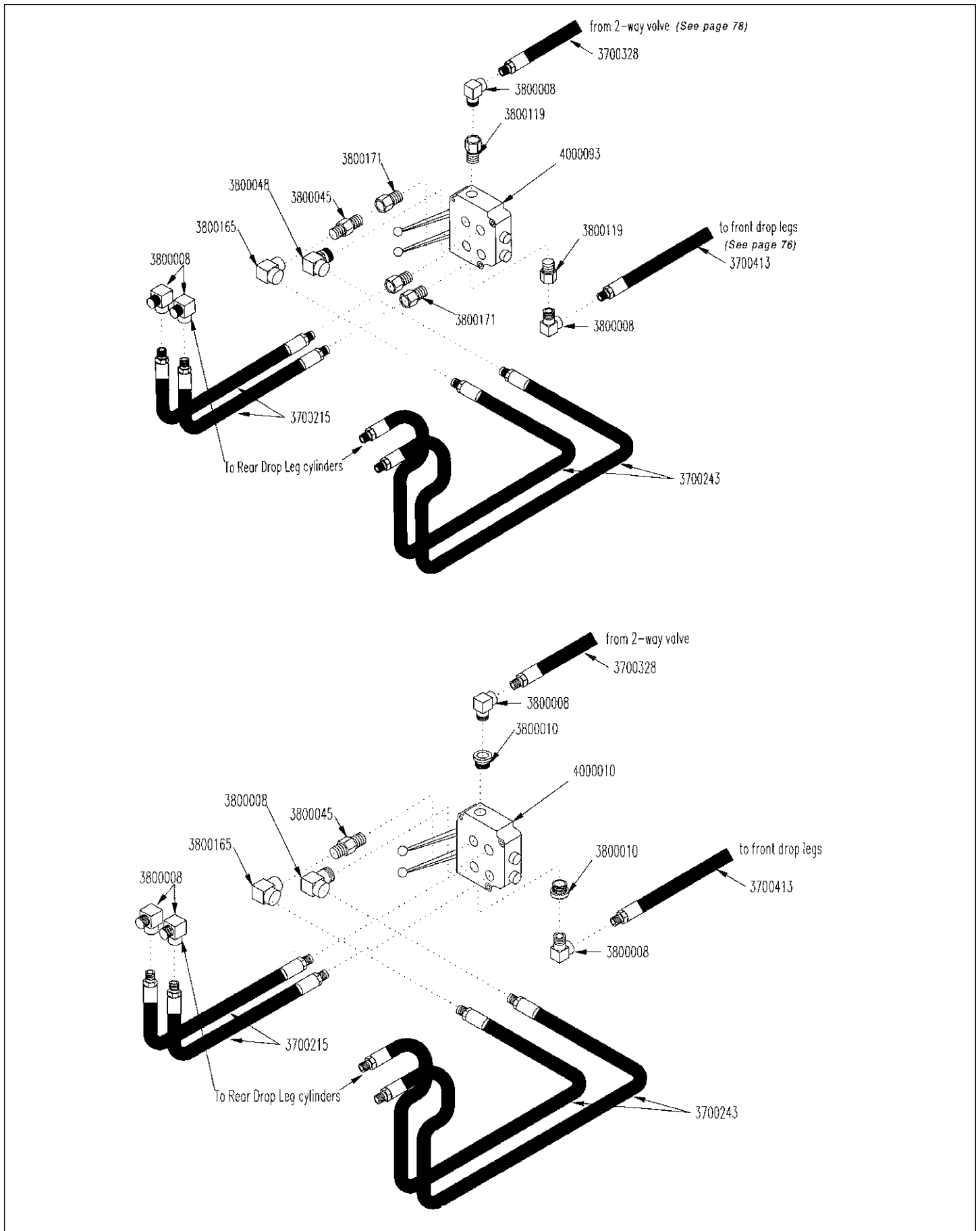



REAR DROP LEG CONTROL

Rear Drop Leg Control, O-Ring

Part No.	Qty.	Description
3700215	2	HOSE\HYD\1/2X17\SW-SW
3700243	2	HOSE\HYD\1/2X100\SW-SW
3800008	4	FTG\1/2MPX1/2FP\90D\ST;EL
3800045	1	FTG\1/2MPX2\NPL
3800048	1	FTG\3/4MORX1/2FP\90D\ST;>
3800119	2	FTG\1-1/16MORX1/2FP\ADPT
3800165	1	FTG\1/2FP\90D\ELL
3800171	3	FTG\3/4MORX1/2FP\ADPT
4000093	1	VALVE\HYD\2-SPL\3POS-4W>

Rear Drop Leg Control, Pipe Thread

Part No.	Qty.	Description
3700215	2	HOSE\HYD\1/2X17\SW-SW
3700243	2	HOSE\HYD\1/2X100\SW-SW
3800008	5	FTG\1/2MPX1/2FP\90D\ST;EL
3800010	2	FTG\3/4MPX1/2FPBUSH
3800045	1	FTG\1/2MPX2\NPL
3800165	1	FTG\1/2FP\90D\ELL
4000010	1	VALVE\HYD\2-SPL\3POS-4W>



FRONT DROP LEG

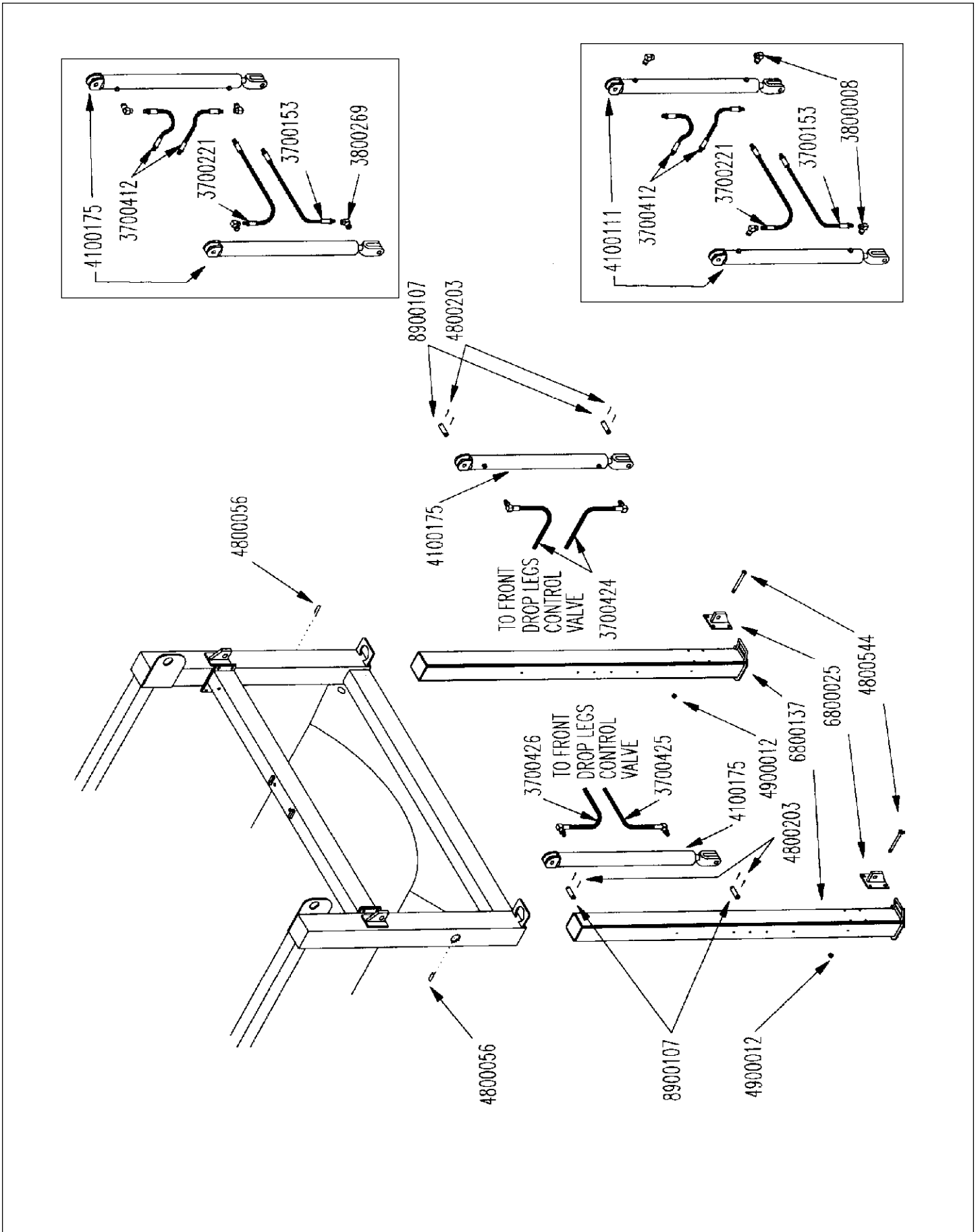



FRONT DROP LEG

6800117 Front Drop Leg

Part No.	Qty.	Description
4800056	2	PIN\HAIR\3\16X3 (#6)
4800203	8	PIN\COT\5\32X2
4800544	8	BOLT\HEX\5\8X6\NC
4900012	8	NUT\TPLCK\5\8\NC
6800025	2	BRKT\CYL\6X5X3-3\8\DROP>
6800137	2	LEG\HYD\96-1\4X5-3\8X>
8900107	4	1"X3-5\8" PIN
3700424	2	HOSE\HYD\1\2X36\7\8\MORS90X1\2\MPS
3700425	1	HOSE\HYD\1\2X108\7\8\MORS90X1\2\MPS
3700426	1	HOSE\HYD\1\2X138\7\8\MORS90X1\2\MPS
4100175	2	CYL\HYD\3X36\PARALLEL\
3700153	1	HOSE\HYD\1\2X108\SW-SW
3700221	1	HOSE\HYD\1\2X138\SW-SW>
3700412	2	HOSE\HYD\1\2X36\SW-SW
3800008	4	FTG\1\2MPX1\2FP\90D\ST;EL
4100111	1	CYL\HYD\3X36\PERP



FRONT DROP LEG CONTROL

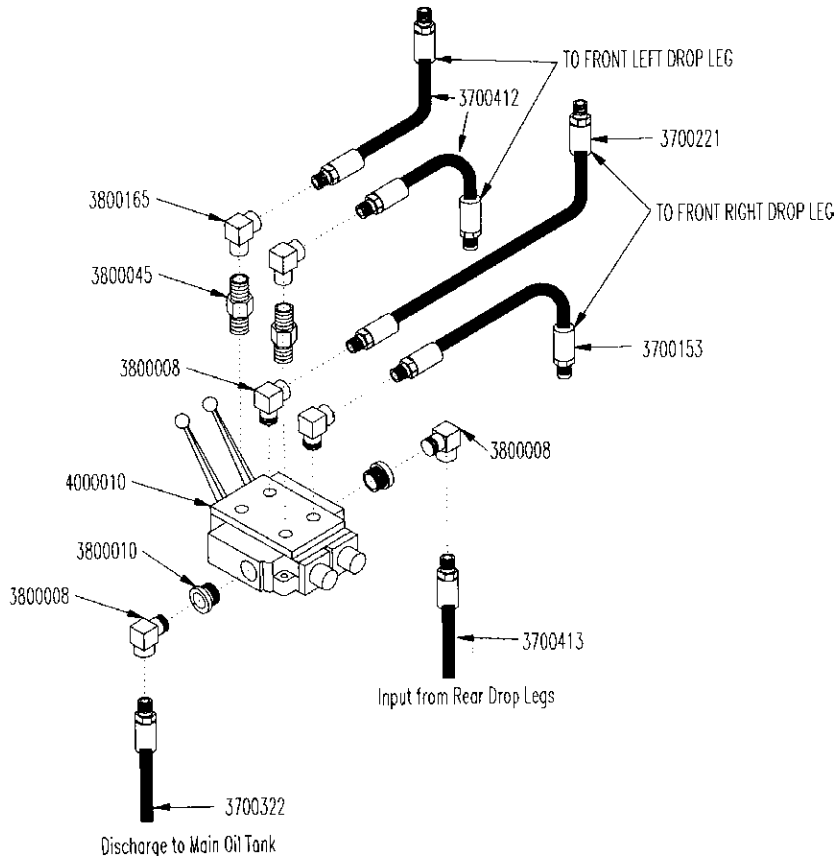
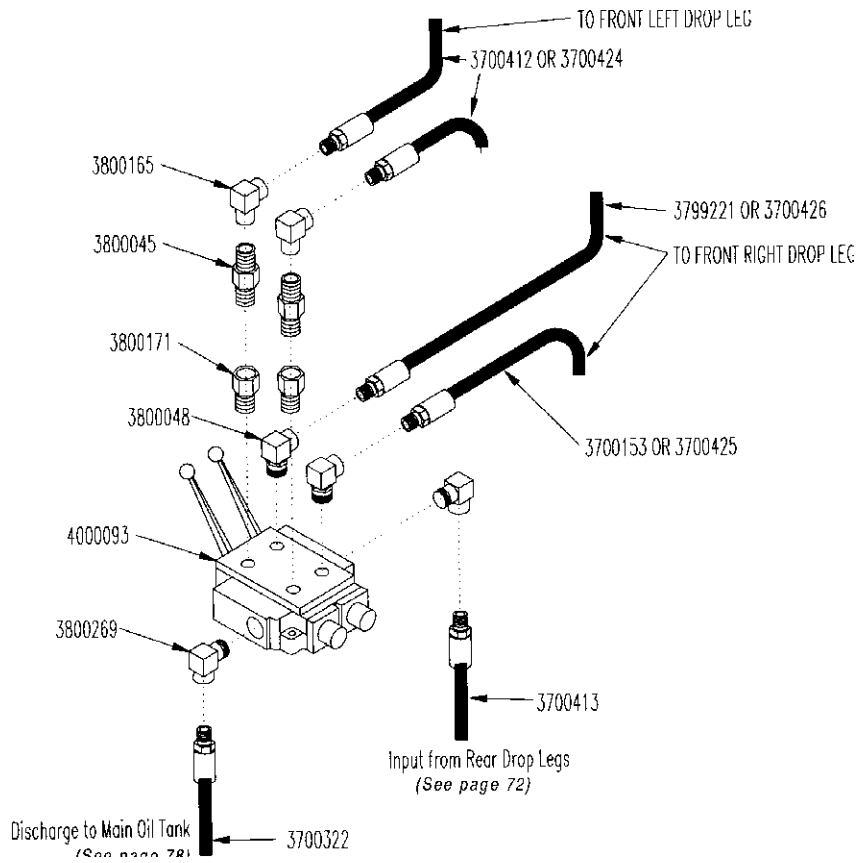



FRONT DROP LEG CONTROL

Front Drop Leg Control, O-Ring

Part No.	Qty.	Description
3700424	2	HOSE\HYD\1/2X36\1/2MPSX>
3700425	1	HOSE\HYD\1/2X108\1/2MPSX>
3700426	1	HOSE\HYD\1/2X138\1/2MPSX>
3800045	2	FTG\1/2MPX2\NPL
3800048	2	FTG\3/4MORX1/2FP\90D\ST;>
3800165	2	FTG\1/2FP\90D\ELL
3800171	2	FTG\3/4MORX1/2FP\ADPT
4000093	1	VALVE\HYD\2-SPL\3POS-4W>

Front Drop Leg Control, Pipe Thread

Part No.	Qty.	Description
3700153	1	HOSE\HYD\1/2X108\SW-SW
3700221	1	HOSE\HYD\1/2X138\SW-SW>
3700412	2	HOSE\HYD\1/2X36\SW-SW
3800008	4	FTG\1/2MPX1/2FP\90D\ST;EL
3800010	2	FTG\3/4MPX1/2FP\BUSH
3800045	2	FTG\1/2MPX2\NPL
3800165	2	FTG\1/2FP\90D\ELL
4000010	1	VALVE\HYD\2-SPL\3POS-4W>



HYDRAULIC ASSEMBLY

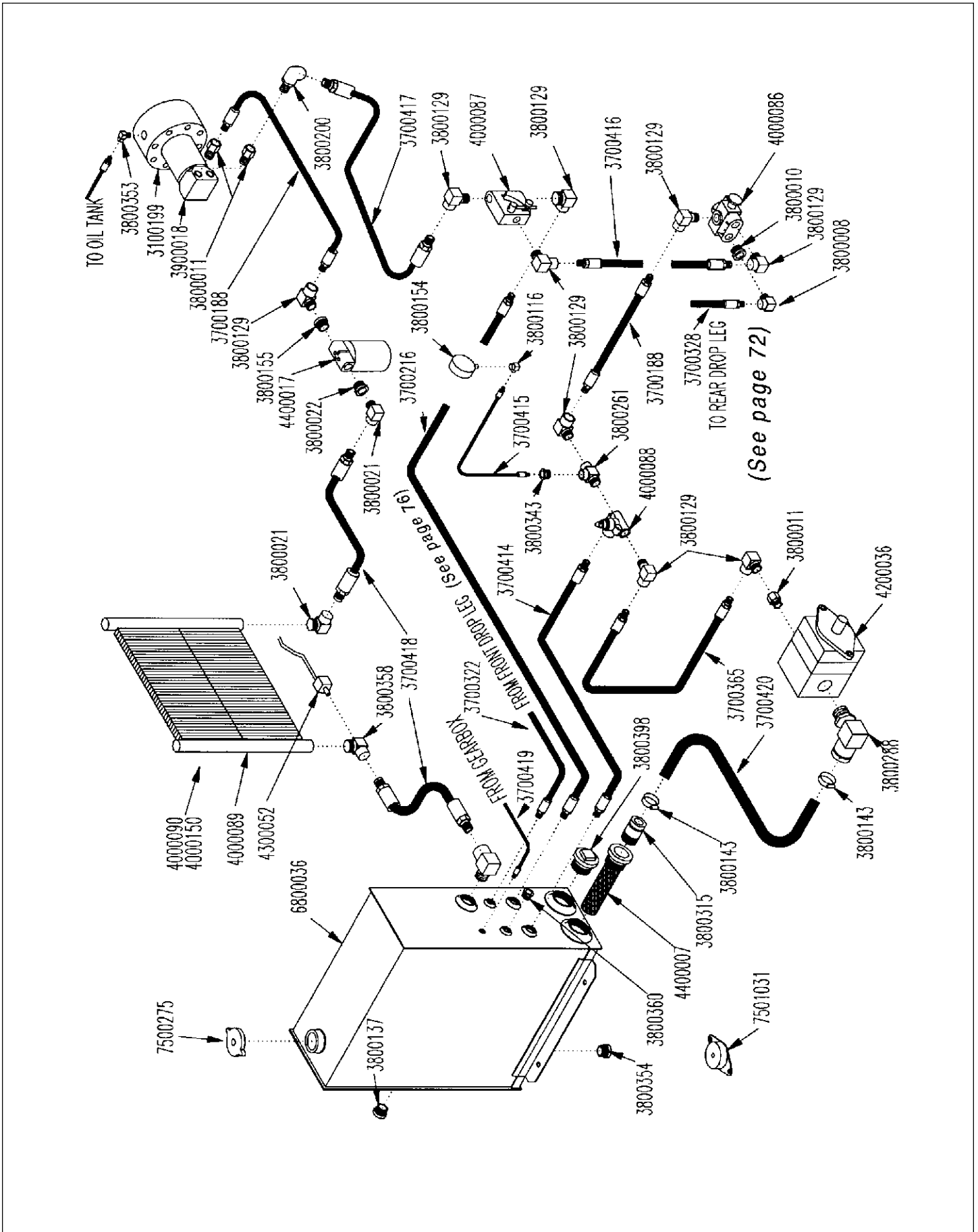



HYDRAULIC ASSEMBLY

6800238 Hydraulic Assembly

Part No.	QTY	Description
3100199	1	GRBX\INLINE\6:1\HECO\SUN>
3700188	2	HOSE\HYD\3\4X36\SW-SW
3700215	2	HOSE\HYD\1\2X17\SW-SW
3700216	1	HOSE\HYD\3\4X67\SW-SW
3700243	2	HOSE\HYD\1\2X100\SW-SW
3700322	1	HOSE\HYD\1\2X290\SW-SW
3700328	1	HOSE\HYD\1\2X28\SW-SO
3700365	1	HOSE\HYD\3\4X30\SW-SW
3700413	1	HOSE\HYD\1\2X264\SW-SW
3700414	1	HOSE\HYD\3\4X38\SW-SW
3700415	1	HOSE\HYD\1\4X38\SW-SO
3700416	1	HOSE\HYD\3\4X12\SW-SW
3700417	1	HOSE\HYD\3\4X55\SW-SW
3700418	2	HOSE\HYD\1X38\SW-SW
3700419	1	HOSE\HYD\1\4X25\SW-SW
3700420	1	HOSE\SUCT\1-1\4X48
3700422	2	HOSE\HYD\1\2X39\7\8MORSX>
3700423	2	HOSE\HYD\1\2X18\7\8MORSX>
3800008	5	FTG\1\2MPX1\2FP\90D\ST;EL
3800010	1	FTG\3\4MPX1\2FP\BUSH
3800011	3	FTG\1-5\16MORX3\4FP\ADPT
3800021	2	FTG\1MPX1FP\90D\ST;ELL
3800022	1	FTG\1-1\4MPX1FP\BUSH\LW
3800045	1	FTG\1\2MPX2\NPL
3800048	1	FTG\3\4MORX1\2FP\90D\ST;>
3800116	1	FTG\1\4FP\90D\ELL
3800119	2	FTG\1-1\16MORX1\2FP\ADPT
3800129	9	FTG\3\4MPX3\4FP\90D\ST;EL
3800137	1	FTG\3\4MP\SIGHT;GLASS
3800143	2	CLAMP\HOSE\1-1\2\T-BOLT>
3800154	1	GUAGE\3000PSI\1\4MP
3800155	1	FTG\1-1\4MPX3\4FP\BUSH\LW
3800165	1	FTG\1\2FP\90D\ELL
3800171	3	FTG\3\4MORX1\2FP\ADPT
3800200	1	FTG\3\4MPX3\4FP\45D\ST;EL
3800261	1	FTG\3\4FPX3\4MPX3\4FP>
3800288	1	FTG\1-5\8MORX1-1\4BARB>
3800315	1	FTG\1-1\4MPX1-1\4BARB>
3800343	1	FTG\3\4MPX1\4FP\BUSH
3800353	1	FTG\3\8MPX1\4FP\90D\ST;>
3800354	1	FTG\3\4MP\PLUG\ALN
3800358	1	FTG\1MPX1FP\90D\ST;ELL>
3800360	1	FTG\1\2MP\PLUG\HEX
3800398	1	FTG\2MP\PLUG\
3900018	1	MTR\HYD\30\BRGLSS\6000>
4000086	1	VALVE\HYD\20GPM\2POS-2WAY
4000087	1	VALVE\HYD\30GPM\FLO;CONT>
4000088	1	VALVE\HYD\30GPM\RELIEF>
4000089	1	RAD\HYD\19-3\4X23X2\1FP
4000090	1	BLWR\HYD\12D\12VDC\KIT
4000150		RAD\MOUNTING\KIT\K-210
4200036	1	PUMP\HYD\30GAL\COM
4300052	1	SWITCH\THRMOSTTC\1>
4400007	1	FLTR\SCRN\2MPX1-1\4FP\
4400017	1	FLTR\COMP\10MICRON\>
4800203	8	PIN\COT\5\32X2
6800036	1	TANK\HYD\TROM
7501031	4	CUSH\IRBBR\5-1\2X3-1\4X1-1\2 Oil Tank Mounts
7501032	4	CUSH\IRBBR\2-1\4X1-1\2\3\8NC Oil Cooler Mounts
8900107	4	1"X3 5/8" PIN



FUEL ASSEMBLY

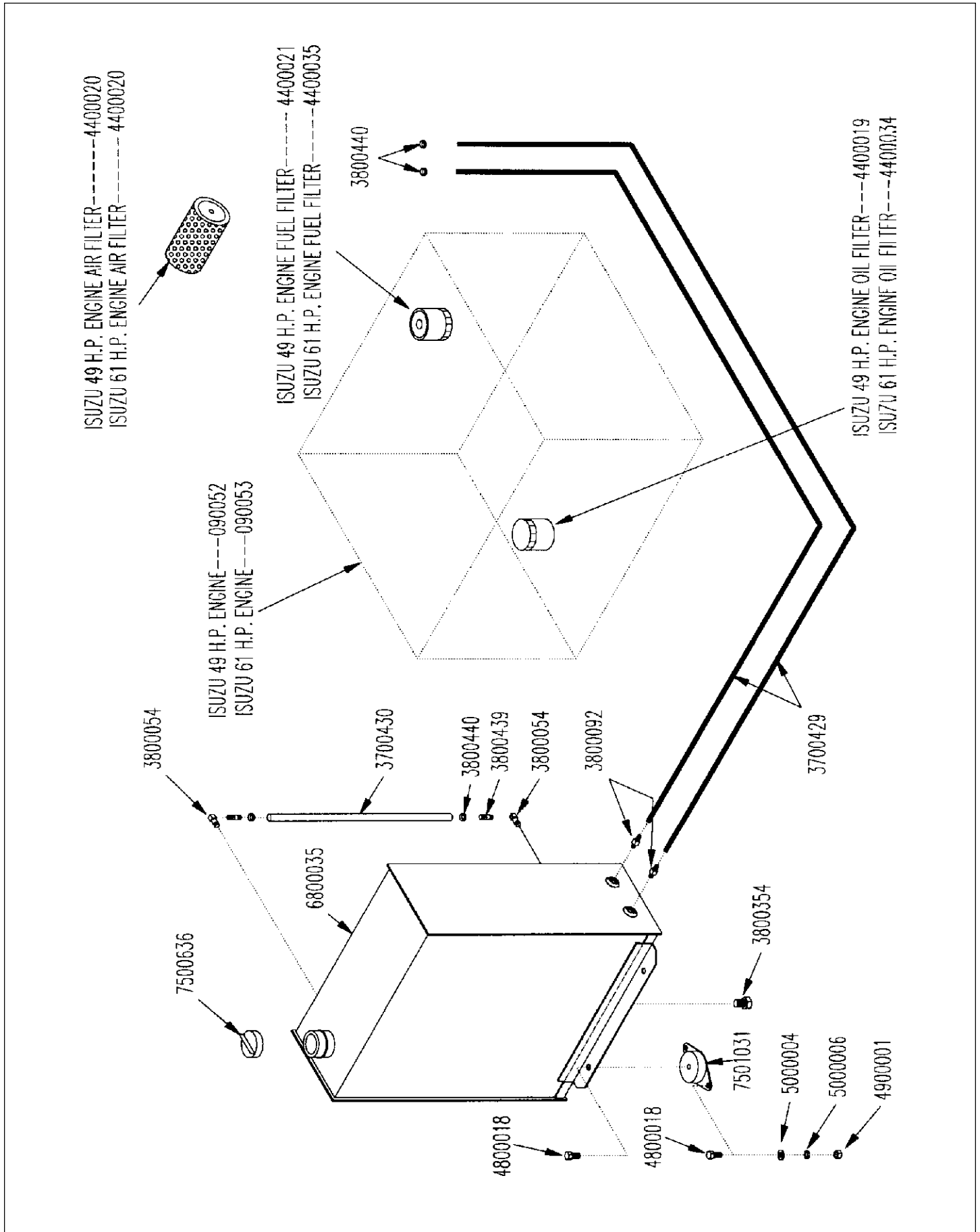



FUEL ASSEMBLY

6800246 Fuel Assembly

Part No.	Qty.	Description
3700429	2	HOSE\FUEL\3/8X80
3700430	1	HOSE\CLEAR\3/8X80
3800054	2	FTG\1/4MPX1/4FP\90D\ST;EL
3800092	2	FTG\3/8MPX3/8BARB\HE>
3800354	1	FTG\3/4MP\PLUG\ALN
3800439	2	FTG\1/4MPX3/8BARBED
3800440	4	HOSE\CLAMP#6
4800018	12	BOLT\HEX\1/2X1-1/4
4900001	8	NUT\HEX\1/2\NC
5000004	8	WASH\FLAT\1/2
5000006	8	WASH\LOCK\1/2
6800035	1	TANK\FUEL\29X24X9-5/8\TRO
7500636	1	CAP\FUEL\LOCKING\4924-4
7501031	4	CUSH\RBBR\5-1/2X3-1/4X>



Electrical Schematic

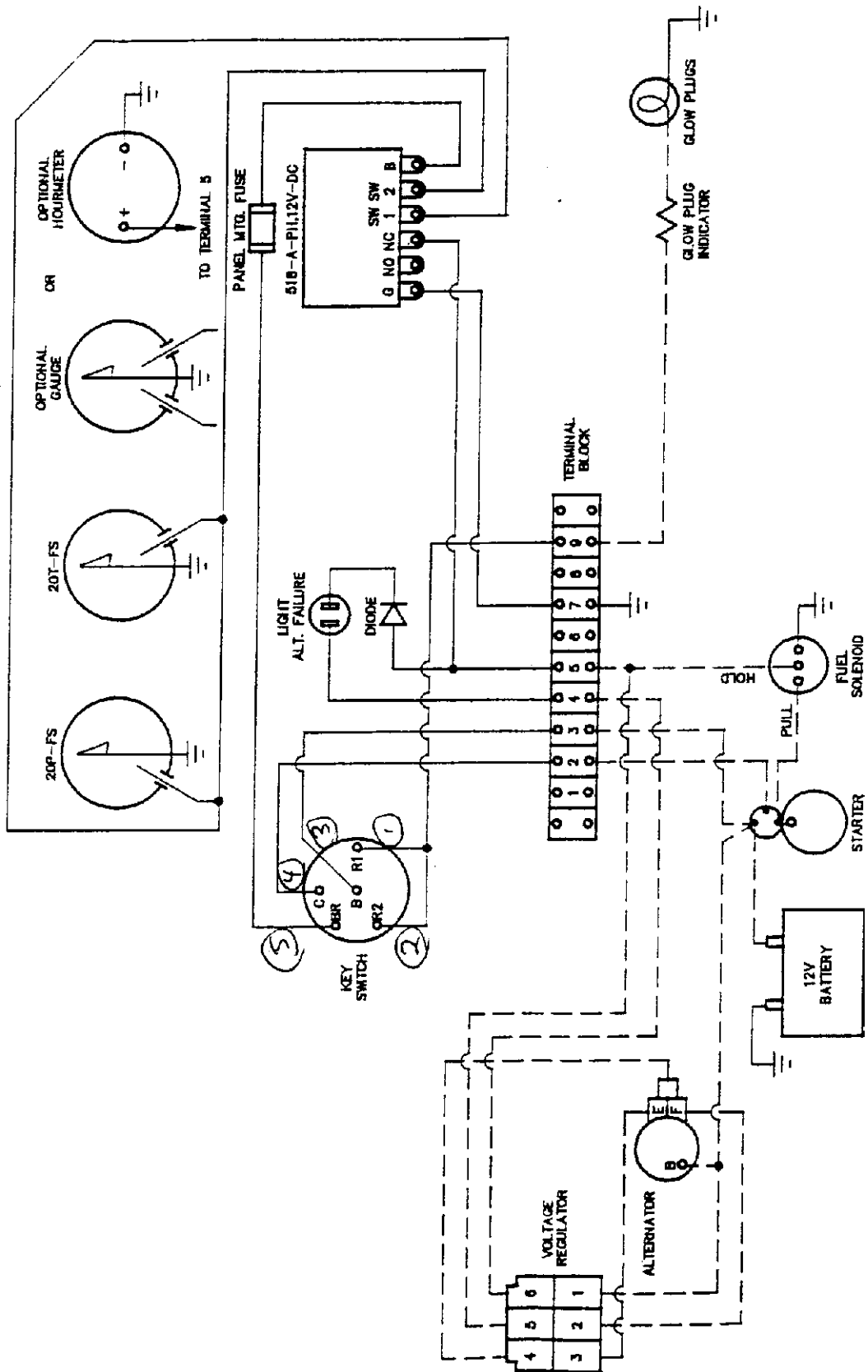



Electrical Schematic

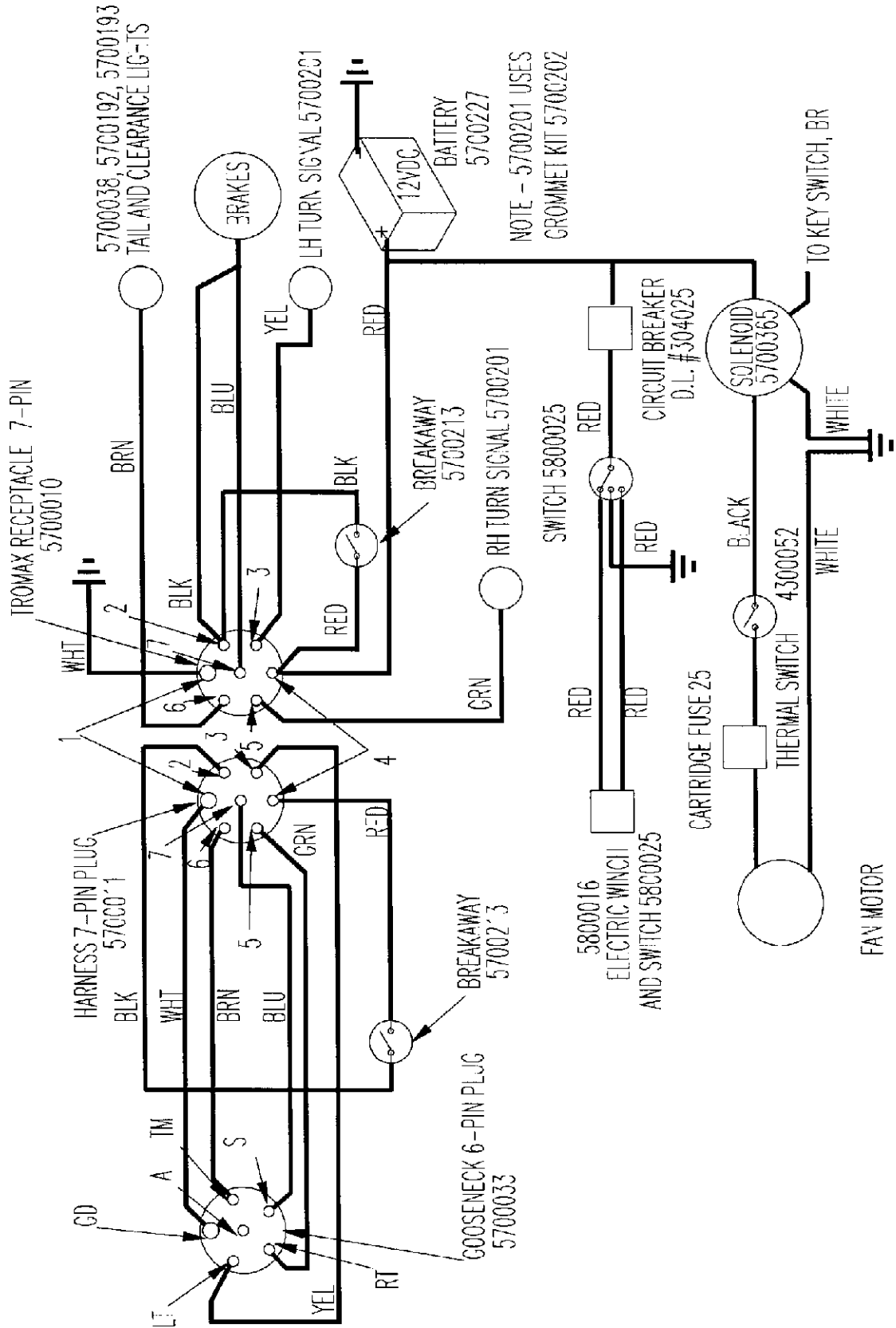





ELECT. SCHEM, PARTS LIST

Part No.	Qty.	Description
4000090	1	BLWR\HYD\12D\12VDC\KIT
4000150	1	RAD\MOUNTING\KIT\K-210
4300052	1	SWITCH\THRMOSTTC\140DEG
5700010	1	TERM\7POLE\TRCK\CONN
5700011	1	TERM\7POLE\TRLR\CONN
5700033	1	TERM\6POLE\TRLR\CONN
5700034	1	ENCL\JCT\7POLE\TRLR\HARN
5700038	2	LAMP\CL\12VDC\AMBER
5700192	4	LAMP\RFLCTR\AMB\4-3/8X>
5700193	2	LAMP\RFLCTR\RED\4-3/8X>
5700201	4	LAMP\TAIL\4-1/2\COMP\RED>
5700202	3	LAMP\GRMMT\2-1/2\KIT\>
5700204	1	TERMBATT\4GA\POS
5700205	1	TERMBATT\4GA\NEG
5700206	2	TERM\RING\4GAX3/8
5700207	5FT	CBL\BATT\BLK\4GA\FT
5700210	1	TERM\CONN\2POLE\MOLDED\>
5700213	4	SWITCH\BRKAWAY\12VDC\>
5700227	1	BATT\12VDC\GRP24
5700365	1	RELAY\CONT:DUTY\12V
5800016		12 VOLT WINCH SA9005
5800025		SWITCH\206007\SA9005



6500039

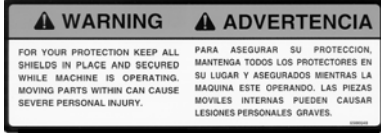

6500040



6500042



6500052

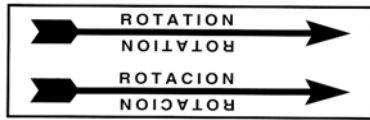

6500056



6500065

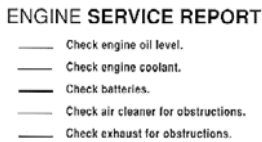

6500132

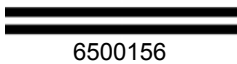

6500219



6500220



6500227



6500227



6500237

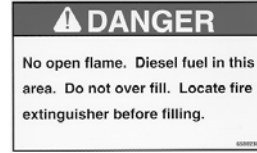

6500238

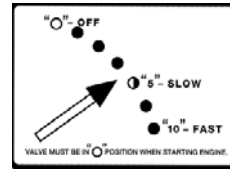

6500239

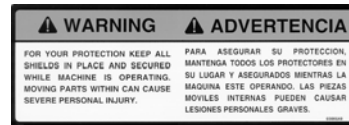

6500240

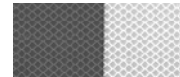

6500245

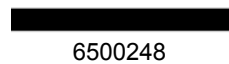

6500248



6500208



**DECAL KIT 7216****6500312 Decal Kit 7216**

Part No.	Qty.	Description
6500039	1	DECAL\INFO\S\NDURATECH
6500040	2	DECAL\WARN\SHIELD;PROT
6500042	1	DECAL\WARN\KEEP;WHL;BLTS>
6500052	1	DECAL\INFO\OIL;LEVEL
6500056	1	DECAL\INFO\ROTATION\STR
6500065	1	DECAL\INFO\PATENT;PENDING
6500124	1	DECAL\INFO\HYD;OIL
6500132	1	DECAL\INFO\ENG;SERV
6500156	50 ft.	DECAL\LOGO\2\STRIPE\SLV
6500157	2	DECAL\LOGO\RECYCLE\SLV
6500208	1	DECAL\WARN\GENERAL
6500219	3	DECAL\DNGR\MOVING;PRTS\>
6500220	2	DECAL\WARN\HI;PRESS;FLUID
6500224	4	DECAL\LOGO\DURA\4-3/4\SIL
6500227	2	DECAL\DNGR\ROT;BARREL
6500228	4	DECAL\LOGO\TROMAX\3\SLV
6500229	4	DECAL\LOGO\7216\3\SLV
6500235	1	DECAL\CAUT\PROP;TOOLS\SW2
6500236	2	DECAL\INFO\MANUAL\BLK;ON>
6500237	2	DECAL\DNGR\AUGER;INT
6500238	1	DECAL\DNGR\OPEN;FLAME
6500239	1	DECAL\INFO\VALVE;SPEED\>
6500240	1	DECAL\WARN\MOVE;PART
6500245	50 ft.	DECAL\MISC\TAPE\RED\WHITE
6500248	5 ft.	DECAL\MISC\RFLCTR\2\WHT



PLANETARY GEARBOX

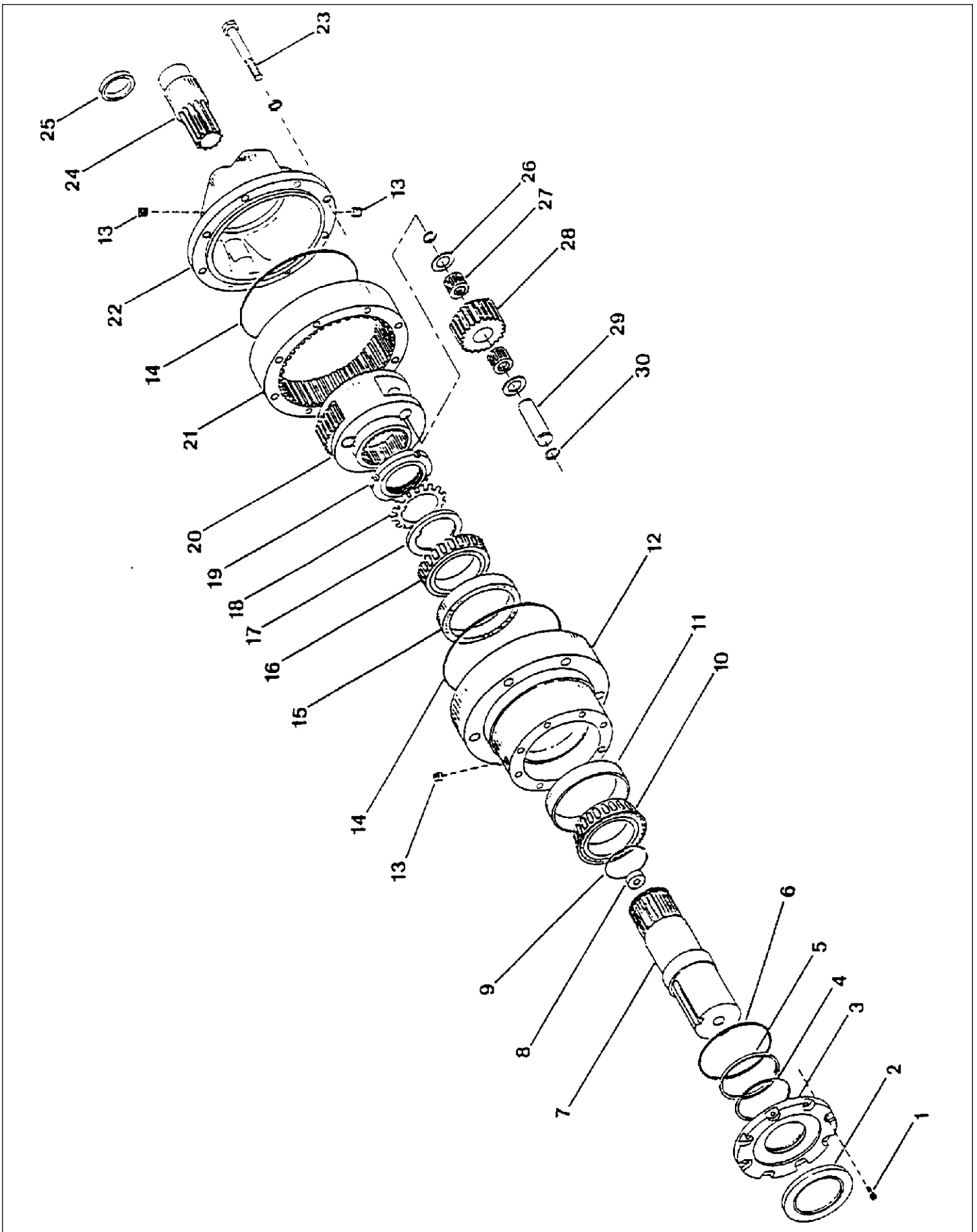



PLANETARY GEARBOX

3100199 Planetary Gearbox

Item	Part No.	Qty.	Description
1	15111	8	Cap Screw
2*	20150	1	Shaft Seal
3	20023	1	Seal Carrier-1 design
	20064		Seal Carrier-2 design'
4*	20119	1	Backup Ring
5*	20117	1	Quad Ring
6*	20116	1	ORing
7	20044	1	Output Shaft 2.750" Straight Keyed
8	150152	1	Thrust Washer
9	20011	1	Retaining Ring
10	20121	2	Cone
11	20112	2	Cup
12	20020	1	Housing
13	20110	3	Pipe Plug
14*	20101	2	O Ring
15	20112	2	Cup
16	20121	2	Cone
17	20128	1	Keyed Washer
18	20106	1	Lock Washer
19	20107	1	Lock Nut
20	20006	1	Planet Carrier
21	20019	1	Internal Gear 6:1
22		1	Motor Adapter
	20024		SAE C 2 & 4-Bolt
	200701		Ross MAB & MAE
23	20109	8	Bolt
24	20G	1	Sun Gear 6:1 6000 Char-Lynn Bearingless
25	20113	1	Bushing (Char-Lynn Bearingless Only)
26	20116	6	Thrust Washer
27	20111	6	Planet Bearing
28	20018	3	Planet Gear 6:1
29	20010	3	Planet Pin
30	20105	6	Retaining Ring
	20932		Seal Kit-BUNA
	20933		Seal Kit-VITON
	20935		Seal Kit-H-P

* Indicates items included in seal kits

NOTE: These items are not normally stocked by DuraTech, but are listed here for your convenience. These parts are manufactured by Heco, Inc. Phone (916) 372-5411



