

A tradition of innovation since 1966



## model TC-15

[ tree chipper ]

DURATECH®



### **DURATECH**...Clearing the way for a better tomorrow.

*The Model TC-15 Tree Chipper is the latest model in DuraTech's growing line of durable and innovative tree chippers.*

- *Designed to grind limbs and trees up to 15" in diameter.*
- *Engine Options: 122 hp (91 kw) CAT C4.4 Diesel Engine  
139 hp (103.7 kw) CAT C4.4 Diesel Engine*
- *Patented Automated In-Feed System: Allows operator to increase down-pressure on top feed roller while starting large logs, which allows operator to walk away as auto feed governing system handles feeding*
- *Optional Radio Remote Control: Operator can increase down-pressure hydraulically or back log out, all from a skid loader*
- *Optional gathering winch for larger, harder to handle logs*
- *Safety Features include: Breakaway Brake Switch, 2 E-Stop Switches, 2 In-Feed Hopper Light Bars, and Disc Hood Closed Proximity Switch*
- *Available with a pintle or ball hitch*



**HPTO**  
Wet Clutch



**2" Thick**  
Chipping Disc



**15" Hydraulic**  
Feed Roller



**Two Control Panels**  
with Emergency Stop



**Patented Automated**  
Feed Sensor



**Easy-Access**  
Anvil

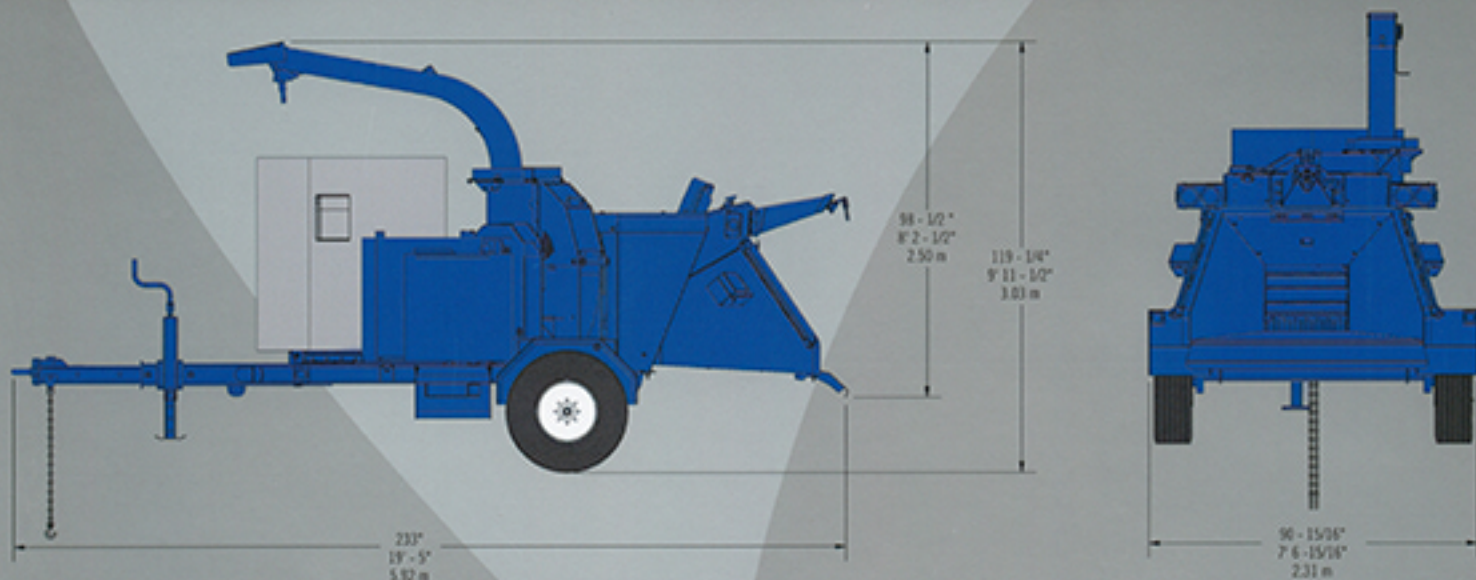

## SPECIFICATIONS

## model TC-15 [ tree chipper ]

<b>Engine</b>	CAT C4.4 122 HP (91 kW) CAT C4.4 139 HP (103.7 kW)	<b>Disc Size</b>	48" (122cm) dia. x 2" (5.08cm)
<b>Gross Weight</b>	8,540 lbs. (3,874kg)	<b>Disc Shaft Size</b>	3-15/16" (10cm) dia.
<b>Transport Width</b>	91" (231.1 cm)	<b>Feed System</b>	Hydraulic 2 Drum
<b>Transport Length</b>	208" (528.3 cm)	<b>Number of Knives</b>	4, 2 slots
<b>Hitch</b>	3" Pintle or 2-5/16" Ball	<b>Size of Knives</b>	4-1/2" (11.5cm) x 9-1/4" (23.5cm) 3-bolt
<b>Tongue Weight</b>	1,140 lbs.(517.1kg)	<b>Feed Wheel</b>	Adjustable Spring load, Patented Automated In-Feed System
<b>Jack</b>	10,000 lbs (4,536kg)	<b>Discharge System</b>	360°, Hydraulic Rotation w/ Adjustable Chip Spout
<b>Axle</b>	8,000 lbs (3,629kg) Torflex	<b>Safety Features</b>	Breakaway Brake Switch, 2 E-Stop Switches, 2 Infeed Hopper Light Bars, and Disc Hood Closed Proximity(0.64 cm) Switch
<b>Suspension</b>	Torsional	<b>Frame Size</b>	3" (7.6cm) x 5" (12.7cm) x 1/4"
<b>Brakes</b>	Electric	<b>Options</b>	2 Function Radio Remote (Controls Feed Direction, Feed Raise/Lower, or Winch In/Out)
<b>Tires</b>	10R 17.5 (16ply)		
<b>Fuel Capacity</b>	40 gal (152 L)		
<b>Hydraulic Oil Capacity</b>	25 gal (95 L)		
<b>Electrical</b>	24V		
<b>Lights</b>	Clearance and Directional		
<b>Transmission</b>	PT Tech HPTO		
<b>Chipping Capacity</b>	15" (30.5cm)		
<b>Infeed Hopper Opening</b>	40" x 64" (102cm x 163cm)		
<b>Throat Opening</b>	15" x 23" (38cm x 58cm)		

*Illustrations, specifications, and descriptions contained herein were accurate at the time of publication, but are subject to change without notice. Illustrations may include optional equipment and accessories and may not include all standard equipment.*

...Clearing the way for a better tomorrow.