

# **INDUSTRIAL GRINDER**

**OPERATORS MANUAL  
PARTS BOOK**

# **IG-7**

## WARRANTY

Haybuster Mfg. Inc., warrants to the original purchaser for 90 days from purchase date that this product will be free from defects in material and workmanship when used as intended and under normal maintenance and operating conditions. This warranty is limited to the replacement of any defective part or parts returned to our factory in Jamestown, N.D., within thirty (30) days of failure.

This warranty shall become void if in Haybuster Mfg. Inc.'s., judgment the machine has been subject to misuse, negligence, alterations, damaged by accident or lack of required normal maintenance, or if the product has been used for a purpose for which it was not designed.

All claims for warranty must be made through the dealer which originally sold the product and all warranty adjustments must be made through same.

This warranty does not apply to tires or bearings or any other trade accessories not manufactured by Haybuster Mfg. Inc. Buyer must rely solely on the existing warranty, if any, of these respective manufacturers.

Haybuster Mfg. Inc., shall **not** be held liable for damages of any kind, direct, contingent, or consequential to property under this warranty. Haybuster Mfg. Inc., cannot be held liable for any damages resulting from causes beyond its control. Haybuster Mfg. Inc., shall **not** be held liable under this warranty for loss of crops, or rental costs or any expense or loss for labor or supplies.

Haybuster Mfg. Inc., reserves the right to make changes in materials and/or designs of this product at any time without notice.

This warranty is void if Haybuster Mfg. Inc., does not receive a valid warranty registration card at its office in Jamestown, N.D., within 10 days from date of original purchase.

All other warranties made with respect to this product, either expressed or implied, are hereby disclaimed by Haybuster Mfg. Inc.



# IG- INDUSTRIAL GRINDER DELIVERY AND SERVICE REPORT

\_\_\_\_\_ Dealer assisted the customer in filling out the warranty registration form.

\_\_\_\_\_ The customer was provided with the appropriate engine operators manual and the grinder operators manual.

\_\_\_\_\_ The dealer read the operator manuals and explained in detail the operation, adjustment procedures, maintenance and safety instructions to customers.

After performing the necessary assembly, check the following items carefully and make corrections when necessary!

## CHECKED AND FOUND TO BE ACCEPTABLE:

\_\_\_\_\_ Check the machine for shipping damage or shortage.

\_\_\_\_\_ Check the machine for loose bolts.

\_\_\_\_\_ Lubricate entire machine according to the lubrication chart found on pages 9-11.

\_\_\_\_\_ Check engine oil level

\_\_\_\_\_ Check engine coolant.

\_\_\_\_\_ Check batteries.

\_\_\_\_\_ Check air cleaner for obstructions.

\_\_\_\_\_ Check exhaust for obstructions.

\_\_\_\_\_ Read Engine Pre-Start-up check list in engine operation manual.

\_\_\_\_\_ Check hydraulic oil level, page 5.

\_\_\_\_\_ Check hydraulic connections for tightness.

\_\_\_\_\_ Check for correct hammer arrangement, page 15.

\_\_\_\_\_ Check for proper function of tub rotation control valve, page 7.

\_\_\_\_\_ Check for proper function of electronic governor, page 7.

\_\_\_\_\_ Check all chains for proper alignment, page 13.

\_\_\_\_\_ Check all chains for proper tension, page 13.

\_\_\_\_\_ Check elevator belt tracking.

\_\_\_\_\_ Check elevator belt tension, page 13.

\_\_\_\_\_ Check condition of tire rims.

\_\_\_\_\_ Check wheel lug bolts for tightness.

- \_\_\_\_\_ Check tires for proper air pressure, page 14.
- \_\_\_\_\_ Check lights for proper function.
- \_\_\_\_\_ Check brakes for proper function.
- \_\_\_\_\_ Check the hydraulic components for leaks.
- \_\_\_\_\_ Verify that all shields are installed and in good condition.
- \_\_\_\_\_ Pointed out all safety shields and explained the importance of keeping all safety shields and covers securely in place. \_\_\_\_\_
- \_\_\_\_\_ Check condition of all safety, operation, and maintenance decals.

I HAVE CHECKED ALL THE ITEMS AND TEST RUN THE MACHINE.  
THIS MACHINE IS READY FOR CUSTOMER USE.

Dealer's Signature \_\_\_\_\_

Model No. \_\_\_\_\_ Serial No. \_\_\_\_\_ Date of Purchase \_\_\_\_\_

*Please return this report with the Warranty Card.*

---

# Table of Contents 1

---

## **OPERATORS MANUAL**

|                           |       |
|---------------------------|-------|
| Safety Instructions ..... | 2-3   |
| Specifications .....      | 4     |
| Before Operating .....    | 5-6   |
| Operation .....           | 7-8   |
| Lubrication .....         | 9-10  |
| Maintenance .....         | 11-13 |
| Hammer Spacing .....      | 14    |
| Trouble Shooting .....    | 15-21 |

## **PARTS BOOK**

|                          |       |
|--------------------------|-------|
| Main Frame (Front) ..... | 22-23 |
| Tub Deck Drive .....     | 24-25 |
| Main Frame (Rear) .....  | 26-27 |
| Cylinder .....           | 28-29 |
| Conveyor .....           | 30-31 |
| Hydraulics .....         | 32-33 |
| .....                    |       |
| .....                    |       |
| .....                    |       |

|                                        |       |
|----------------------------------------|-------|
| Prefilter (Cummings Engine Only) ..... | 39    |
| Electronic Governor .....              | 40-41 |
| Lights - Wiring Schematic .....        | 42-43 |
| Pressure Roller .....                  | 44    |
| Hydraulic Valve .....                  | 45    |
| Tub Drive Motor .....                  | 46    |
| Orbit Motor .....                      | 47    |
| Power Shaft .....                      | 48-49 |
| Decals .....                           | 50-51 |

## **OPTIONS**

|                    |       |
|--------------------|-------|
| Paper Grate .....  | 52-53 |
| Tub Agitator ..... | 54-55 |

---



---

## 2 Safety Instructions

---

The safety of the operator is of great importance to Haybuster Manufacturing Company. We have provided decals, shields and other safety features for your protection. In addition, we ask you to be a careful operator who will properly use and service your Haybuster equipment.

---

**WARNING: BEFORE ATTEMPTING TO OPERATE YOUR GRINDER, CAREFULLY READ AND FOLLOW INSTRUCTIONS GIVEN BELOW AND CONTAINED ELSEWHERE IN THIS MANUAL.**

1. Read and follow all instructions contained in:
  - a. this grinder operator's manual
  - b. engine operator's manual
  - c. decals placed on the grinder.

**NOTE: Additional copies of the above mentioned materials can be obtained from your dealer.**

2. Be sure all safety shields and covers are securely in place when machine is running.
3. Allow only responsible, properly instructed individuals to operate machines. Carefully supervise inexperienced operators.
4. Make no modifications to this equipment unless specifically requested or recommended by Haybuster Manufacturing Co.
5. Tighten or replace any loose or cracked bolts, chains, hoses or connections.
6. Check overhead for electrical power lines or other obstructions and be certain there is adequate clearance.
7. Make sure the machine is in good operating condition and that all protective shields are in place and in proper working order. Replace damaged shields before operating.
8. Check periodically for breaks or unusual wear and make any necessary repairs.
9. Allow no one to ride on the grinder at any time.
10. **REMEMBER:** Loose clothing, necklaces and similar items are more easily caught in moving parts. Avoid the use of these items if possible and keep long hair confined.

11. Watch out for and avoid any object that might interfere with the proper operation of the machine.
12. Keep hands, feet and clothing away from power driven parts.
13. **OBJECTS THROWN BY MACHINE.** Do not operate without wearing safety glasses and a hard hat. Keep unauthorized personnel out of the grinding area!

### **DURING SERVICE AND MAINTENANCE**

1. Before working on or near grinder for any reason, including servicing, inspecting or unclogging machine:
  - a. disengage power to grinder
  - b. place transmission in park or set park brake
  - c. shut off engine and remove key
  - d. wait for all movement to stop.
2. When replacing any part on your grinder, be sure to use only Haybuster authorized parts.
3. Relieve all pressure in the hydraulic system before disconnecting the lines or performing other work on the system. Make sure all connections are tight and the hoses and lines are in good condition before applying pressure to the system.
4. Hydraulic fluid escaping under pressure can be invisible and have enough force to penetrate the skin. When searching for a suspected leak, use a piece of wood or cardboard rather than your hands. If injured, seek medical attention immediately to prevent serious infection or reaction.

### **WHEN TRANSPORTING ON PUBLIC ROADS**

1. Use good judgment and drive carefully, especially over rough and uneven roads.
  2. Be sure brakes are properly adjusted.
  3. Check your state laws regarding the use of lights, slow moving vehicle sign, safety chain and other possible requirements.
  4. Be aware of machine width at all times; do not exceed 55 mph.
-

**WARNING: FAILURE TO COMPLY WITH ANY OF THE PRECEDING SAFETY INSTRUCTIONS OR THOSE THAT FOLLOW WITHIN THIS MANUAL MAY RESULT IN SEVERE INJURY OR DEATH.**

**THIS GRINDER IS NOT TO BE USED FOR ANY PURPOSE OTHER THAN THAT FOR WHICH IT IS INTENDED AS EXPLAINED IN THE OPERATOR'S MANUAL, ADVERTISING MATERIALS AND OTHER PERTINENT WRITTEN MATERIAL PREPARED BY HAYBUSTER MANUFACTURING.**

### **SAFETY DECALS**

Safety decals located on your machine contain important and useful information that will help you operate your equipment safely.

To assure that all decals remain in place and remain in good condition, follow the instructions given below:

1. Keep decals clean. Use soap and water — not mineral spirits, adhesive cleaners, and other similar cleaners that will damage the decal.
  2. Replace any damaged or missing decals. When attaching decals, surface temperature of the metal must be at least 40° Fahrenheit. The metal must also be clean and dry.
  3. When replacing a machine component to which a decal is attached, be sure to also replace the decal.
  4. Replacement decals can be purchased from your Haybuster dealer.
-

---

## 4 IG- Specifications

---

---

Tub Width: 7 Ft. 2 In.

Length: 17 Ft.

Height: 7 Ft.

Weight: 6500 with Engine

Inside Tub Diameter: 5 Ft.

Screen Area: 1,458

Hammermill: 27½ Inc. (½" Cylinder Plates)

Hammers: 32 — Half Inch A.B. Hardened

Feed: 7 Ft 6 In. Folding Conveyor 18" Wide

Axle: 6,000 lbs. Single, Equipped with Electric Brakes

Tire Size: 7.5 x 15

Lights: Clearance and Directional Tail Lights

Governor: Electro-Hydraulic Sensing Governor

Cylinder Shaft Diameter: 3 In. Stress Proof Steel

Height to Top of Tub with Flair: 6 Ft., 11 In.

Hydraulic Oil: 19 Gal.

Diesel Fuel: 29 Gal.

Record the Model and Serial Number from your unit in space below. Always refer to the Model and Serial Number of your unit with all parts orders or with any correspondence regarding it.

Model Number \_\_\_\_\_

Serial Number \_\_\_\_\_

Date of Purchase \_\_\_\_\_

---



All machines have been pre-run at the factory to assure all functions are operating properly. The hydraulic reservoir tank contains approximately 12 gallons of hydraulic oil for **test running only**. Before operating your machine, additional oil must be added to the reservoir tank. It will take approximately 7 more gallons of hydraulic oil. This should bring the oil level to within 4" below the top of the reservoir.

**CAUTION: Lack of proper hydraulic oil level in the reservoir tank will cause system to heat under continuous running. (Recommend Mobil 423, Co-op Super HTB or similar oil.)**

**CAUTION: In extremely cold weather, it may be necessary to add a gallon of kerosene to the reservoir tank to thin down the oil.**

### PRE-OPERATING CHECKS

Before operating the Tub Grinder, follow these instructions:

1. Read and have a thorough understanding of the operator's manual, especially the sections pertaining to machine operation and safety.
2. Be sure anyone who will assist you in the operation of this machine knows how the machine operates.
3. Know the machine's safety features and understand the safety precautions.
4. Be sure all lubrication points have been lubricated.
5. Give the machine a "once-over" for any loose bolts.
6. Make sure machine is properly adjusted. See Adjustments, pages 9 through 13.
7. Always grind with the machine stationary.
8. Start the machine and check the tub direction, speed control governor for proper operation.
9. In cold weather, allow five minutes for the machine to warm up before grinding.
10. Make sure all shields and guards are in place.

## 6 Before Operating

### SCREEN SELECTION

All Haybuster grinders have two screens. They come equipped from the factory with a 2" diameter hole screen and a 3" diameter hole screen. Any combination of hole sizes may be used.

If a combination is used, the smallest hole diameter should be placed on the side of the cylinder box where the material enters the cylinder.

The coarseness of the material to be ground is determined by the hole size in the screens. Hole sizes can vary from 1/2" diameter through 4" diameter. The larger the hole diameter, the courser the grind.

### SCREEN SELECTION

Round perforated screens available are: 1/2", 5/8", 3/4", 1", 1-1/2", 2", 3", 4".

Plate screens, slotted screens and dummy screens are available.

### INSTALLING A SCREEN

**CAUTION: Disengage PTO and shut off engine before entering tub.**

1. Loosen and remove bolts on the screen holding down clip.
2. With a large hook or bar, pull the screen from its chamber.
3. Make sure material is clear from screen holders.
4. Insert the new screen.
5. Replace the hold down clip and bolts. Tighten all bolts securely.

**CAUTION: Keep all foreign objects out of the tub and away from the mill. Foreign objects may result in personal injury or damage to the machine.**

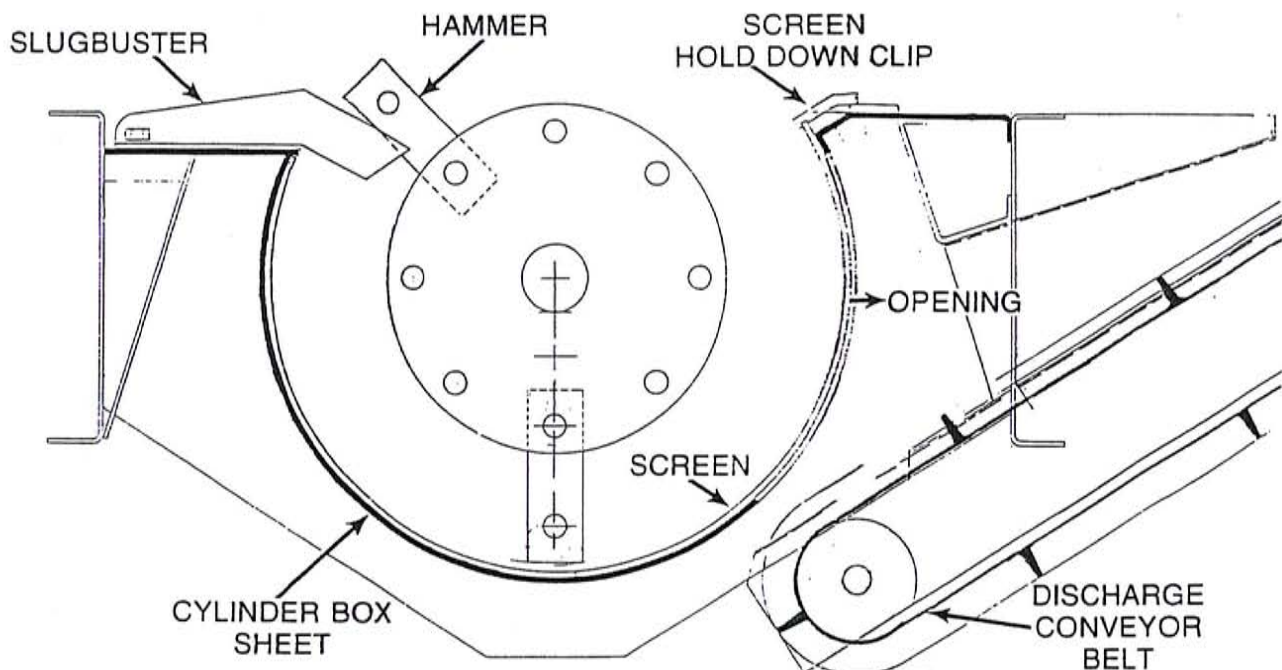

CYLINDER  
REAR VIEW



**NOTE: A fire extinguisher should be handy at all times due to the possibility of sparks from engine or hammers hitting a foreign object.**

## INTRODUCTION

The Electronic Governor controls the feed rate to keep the engine at its peak power point. The operator is able to select the operating range so that when the feed of material lugs down the engine. The Electronic Governor will stop the feed at a high enough PTO speed to the engine to recover automatically if a slug is encountered.

## OPERATION

The Electronic Governor monitors the speed of the engine. The hydraulic flow to the feed mechanism is regulated proportionally to the engine PTO speed. The flow is cut back, slowing the feed, as the PTO speed slows and is increased, increasing the feed, as the PTO speeds up. The regulation range is moved by adjusting the "engine rpm" knob on the front of the governor. Turning the "engine rpm" knob counter clockwise will increase the load on engine by keeping the feed (tub rotation) engaged at a lower engine rpm.

Turning the "engine rpm" knob clockwise will decrease load on engine by disengaging the feed (tub rotation) at a higher engine rpm. **Note: With control box switched to manual, the tub will continue to rotate regardless of engine rpm.**

1. When first starting machine, run at less than full throttle to allow hydraulic system to warm up before operating. In extremely cold weather, it may be necessary to add a gallon of kerosene to the hydraulic reservoir to thin down the oil.
2. With engine running at full throttle, set control box engine rpm dial to max position and set toggle switch in auto position. Engage tub control lever. Check indicator light on your control box before doing any adjusting! At this point, the auto light should be lit. If it is not, read the trouble shooting section, pages 15 through 21.

3. If tub is not turning, turn the "engine rpm" knob counter clockwise until tub begins to rotate. If you are unable to engage tub, read trouble shooting section, pages 15 thru 21.
4. If tub is turning, you are ready to proceed to the grinding section of this book. Remember the "engine rpm" knob adjusts the load placed on the engine and under normal conditions will be the only adjustment you will have to make!

Haybuster Manufacturing test runs every grinder before it leaves the factory. The control box was calibrated at this time and should not need any further adjustment. Before attempting to adjust the control box, read the trouble shooting section, pages 15 thru 21.

## GRINDING

Materials to be ground should be placed directly into the tub. The best method for filling the tub is:

1. Fill the tub about half full of unground materials before starting tub rotation.
2. Start tub.
3. Place additional materials in the tub.

## WET MATERIAL

This is the toughest material for any grinder to handle. When filling the tub with wet material, deposit small quantities on a more frequent basis rather than filling the tub with one load.

**IMPORTANT: Never drop a large object into the tub from a high level. Ease the material over the edge and down into the tub carefully.**

## IF LODGING OCCURS

Occasionally materials may lodge against the side of the tub and not feed down to the mill. If this occurs, reverse the tub direction for about two rotations and then start the tub in a clockwise direction again. This practice normally dislodges any materials.

---

---

## 8 Operation

---

**CAUTION:** Never attempt to dislodge material inside the mill when the machine is in operation by physically pushing materials down. **WHEN THE MACHINE IS IN OPERATION, STAY OUT OF THE TUB.**

### STOPPING THE MACHINE

**CAUTION:** The stored up energy in the cylinder causes it to rotate long after the engine PTO has been disengaged. Before performing any maintenance on the machine or getting into the tub, be sure cylinder and all moving parts have come to a complete stop.

### TRANSPORTING

**CAUTION:** DO NOT MOVE TUB GRINDER without first securing the conveyor in transport position.

### TO PREPARE FOR ROAD TRANSPORT

1. Fold and secure the discharge conveyor.
  2. Hitch jack should be in "up" position.
  3. Machine should be hitched to the towing vehicle with a safety chain.
  4. Check local ordinances regarding restrictions for machine travel on local roads.
  5. Minimum weight of towing vehicle must be 5,500 lbs. Do not tow at speeds exceeding 55 mph.
-



**CAUTION: Always shut off machine before adjusting or lubricating.**

**Hydraulic oil reservoir capacity:** (19 gallons)  
Change hydraulic oil and filter at least once a year.

When grinder is operated during cold weather, all lubrication should be performed after bearings are at operating temperatures.

**BEARING LUBRICATION**

Bearings operating in the presence of dust and water should contain as much grease as speed will permit, since a full bearing with a slight leakage is the best protection against entrance

of foreign material. In the higher speed ranges, too much grease will cause overheating.

High speed operation, abnormal bearing temperature may indicate faulty lubrication. Normal temperature may range from "cool to warm to the touch" up to a point. Unusually high temperatures "too hot to touch for more than a few seconds" accompanied by excessive leakage of grease indicates too much grease. High temperatures with no grease showing at the seals, particularly if the bearing seems noisy, usually indicates too little grease. Normal temperature and a slight showing of grease at the seals indicate proper lubrication.

The following chart is a general guide for relubrication. Certain conditions may require a change of lubrication periods as dictated by experience.

**LUBRICATION CHART**

| Ref. No. | Location            | No. of Zerks | Frequency                     |
|----------|---------------------|--------------|-------------------------------|
| 1        | Tub Drive Shaft     | 2            | 40 Hrs.                       |
| 2        | Tub Rollers         | 8            | 40 Hrs. *                     |
| 3        | Discharge Conveyor  | 4            | 40 Hrs. *                     |
| 4        | Cylinder            | 2            | 10 Hrs. *                     |
| 5        | Tub Pressure Roller | 4            | Annually                      |
| 6        | Wheel Bearings      |              | Annually                      |
| 7        | P.T.O.              |              | 40 Hrs. *                     |
| 8        | Roller Chains       |              | Oil Daily in Dusty Conditions |

Refer to bearing lubrication for the following. \*



# 10 Lubrication

**NOTE:** Reference numbers on the following pictures correspond with the lubrication chart. See page 9.

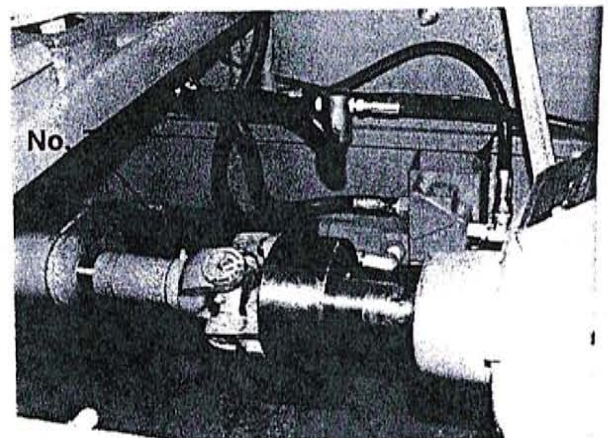
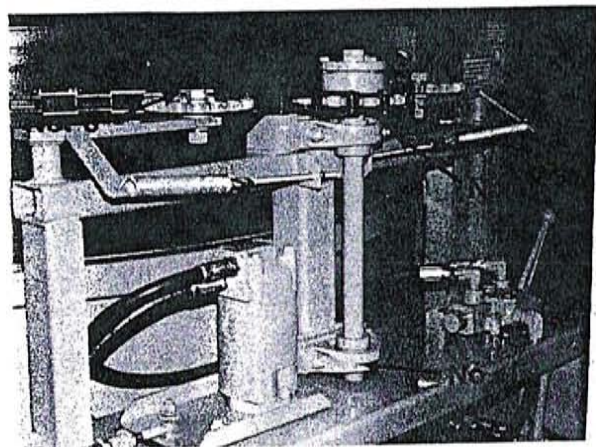
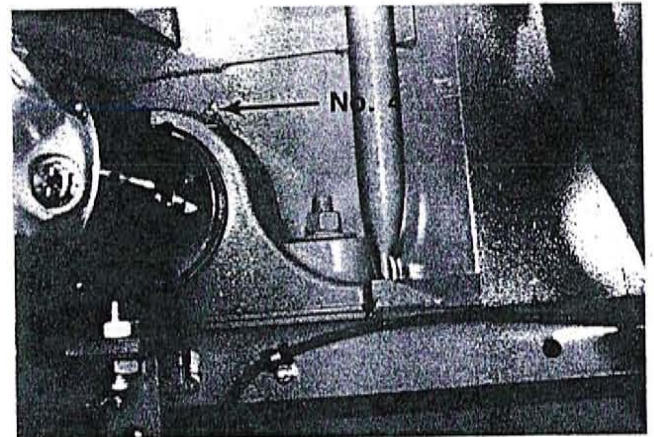
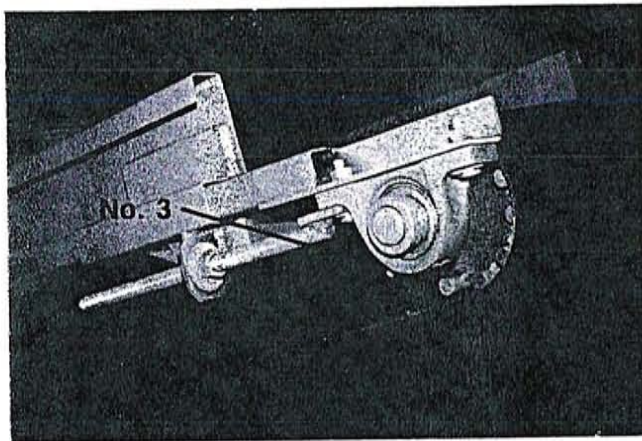
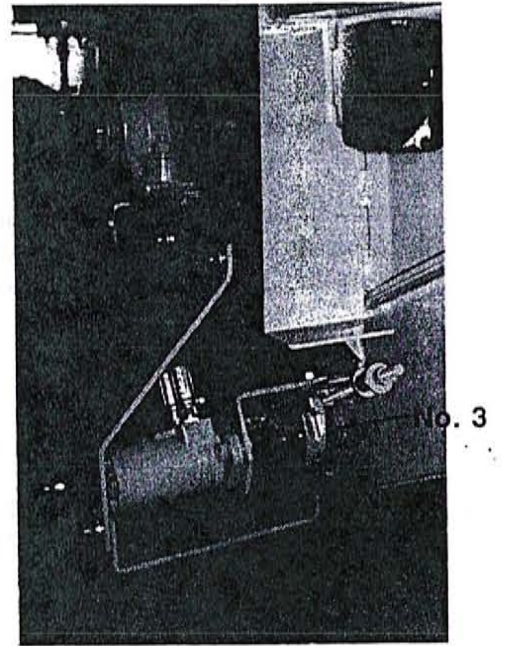
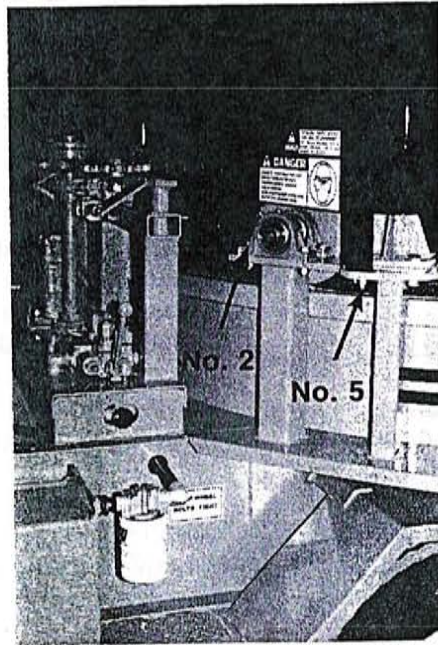



## MAINTENANCE

**WARNING:** Before servicing machine, read the Service and Maintenance section of the Safety Instructions.

**CAUTION:** If for any reason arc welding is to be done, always ground cylinder to frame of machine to prevent arcing in bearings.

**HAMMERS:** Because of the high capacity of the machine, the hammers will wear and must be considered expendable. Each hammer has four cutting corners. For maximum life, it is suggested that hammers be rotated periodically to even out the wear over the entire hammer.

### HAMMER AND SCREEN CONDITION

Cylinder hammers and screens are the heart of the grinder. If cutting edges of the hammers become rounded, hammers should be replaced or turned to expose a new cutting edge. Each hammer has four cutting edges. If end of hammer is allowed to wear too long, one cutting edge is lost. Also badly worn hammers weaken area around hole in hammer so it cannot be turned end for end.

Screens have two cutting edges. When home cutting edges become rounded, screen can be turned end for end exposing new cutting edges.

The results of badly worn hammers and screens is loss of capacity, and added horse power requirements.

**NOTE:** Hammer and hammer rod life can be extended by keeping cylinder rotating at 2000 rpm. Too much engine horse power and/or over feeding the cylinder will cause the hammers to lay back resulting in excessive wear on both hammers and rods!

**HAMMER RODS:** Rods can be turned end for end exposing a new surface area for wear. This will extend service life although hammer rods must be considered expendable.

**CAUTION:** Keep all foreign objects out of the tub and away from the mill. Foreign objects may result in personal injury or damage to the machine.

## HAMMER REPLACEMENT

**CAUTION:** Disengage PTO and shut off engine before entering tub.

To install new hammers or change the cutting edge on existing hammers, tub floor should be free of all material for easy access to cylinder and front cylinder bearing cover.

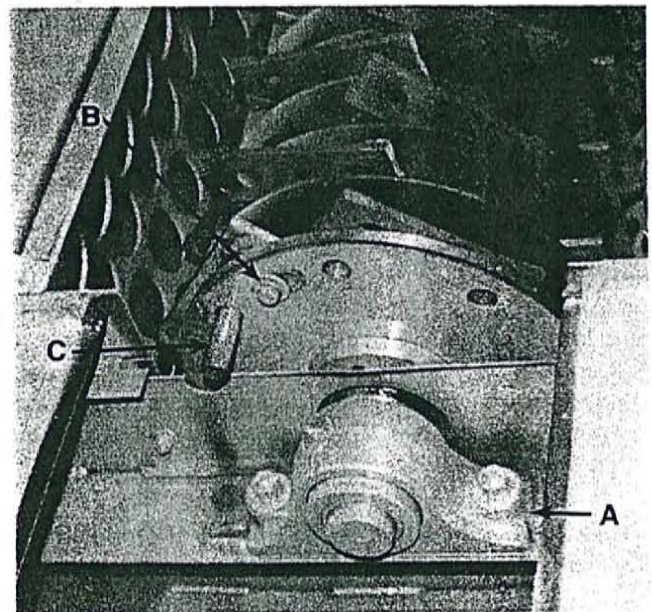

1. Remove front cylinder bearing cover. Item A illustration.
2. Loosen two bolts at front of cylinder which holds the hammer rod retainer plate in place. Item B in illustration.
3. Rotate retainer plate counter clockwise to align holes allowing hammer rods to be removed through front of cylinder. Item C in illustration.
4. Remove one row of hammers and replace, taking note as to where spacers are located. (Separate sheet shows proper spacer location.)
5. After all hammers have been replaced, re-assemble retainer plate and rear cylinder bearing cover.



## 12 Maintenance

### IMPORTANT

Care should be exercised when replacing only a few hammers and not the whole set. If one or more new hammers are inserted on a rod, the same number of new hammers should be inserted on the rod directly across the cylinder. This will maintain a balanced cylinder for vibration free operation.

**CONVEYOR BELTS:** Discharge conveyor upper roller is adjustable to allow for belt stretch. If conveyor belt slows down or stops during operation, tighten both adjusting bolts equally to keep belt centered on upper roller. Due to the discharge conveyors length, the belt will sag on the lower side. This is normal and belt tightness should be judged on slippage.

**CAUTION:** Do not over tighten conveyor belts. Adjust to prevent slippage on drive roller. If belt does not run centered on bottom drive roller, loosen right hand bearing bolts and adjust to force belt to center of roller. Be sure to tighten bolts after correction is made.

1. Check for loose chains or sprockets loose on shaft, badly worn chains.
2. Keep sprockets aligned.
3. Inspect cylinder and all rotating parts for wrapped twine or wire build up.
4. If machine is going to set for an extended period of time, tub floor should be cleaned to prevent rust and sticking problems at start up time.

5. Tub drive chain is equipped with a spring tensioned idler.
6. Due to normal wear, drive chain may tend to climb on driving knobs of tub. If this should occur, the chain should be sized to fit the tub, and the tub knobs adjusted for proper spacing in the chain. Step 1 (sizing the chain). Loosen tub knobs and rap the chain around tub. (Do not run the chain around tightener rollers or drive gear.) Using  $\frac{1}{2}$ " bolt, pull chain together so center to center on link pins marches pins on connector link. If the distance is less or greater than the connector link, shims must be added. Equally space shims of equal thickness and length under chain until proper distance is obtained. Do not add shims under tub knobs. (See illustration.) Step 2. Adjust tub knobs so all three knobs contact chain link on the same side of the knobs. Tighten bolts holding knobs in place and return chain to working position.

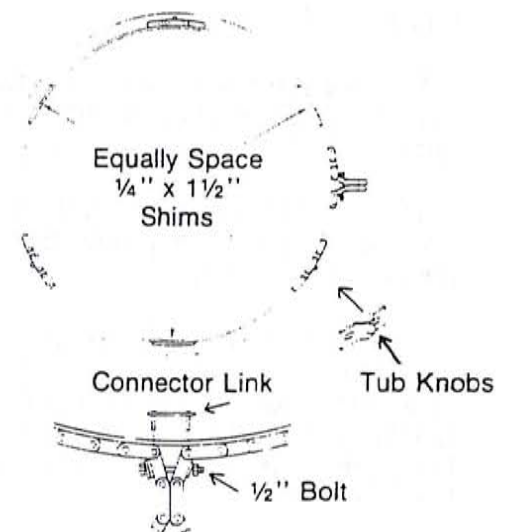



**Tire Pressure:** The proper tire pressure is 50 psi.

**Pressure Roller:** The grinder has a pressure roller with tapered roller bearing. The bearings should be checked for lubrication and adjustment annually, preferably at the end of the season.

If a generous amount of grease is on the bearing and in the housing, and if the grease is soft, the grease will not need changing.

If the lubricant is caked and the bearing seems dry, the bearing should be washed to remove old grease. Repack the bearings.

**Wheel Bearings:** The wheels have tapered roller bearings. The bearings should be checked for lubrication and adjustment annually, preferably at the end of the season.

If a generous amount of grease is on the bearing and in the housing, and if the grease is soft, the grease will not need changing.

If the lubricant is caked and the bearing seems dry, the bearing should be washed to remove old grease. Repack the bearings.

**Electric Brakes:** The electric brakes should be inspected periodically.

---

# 14 Hammer Spacing

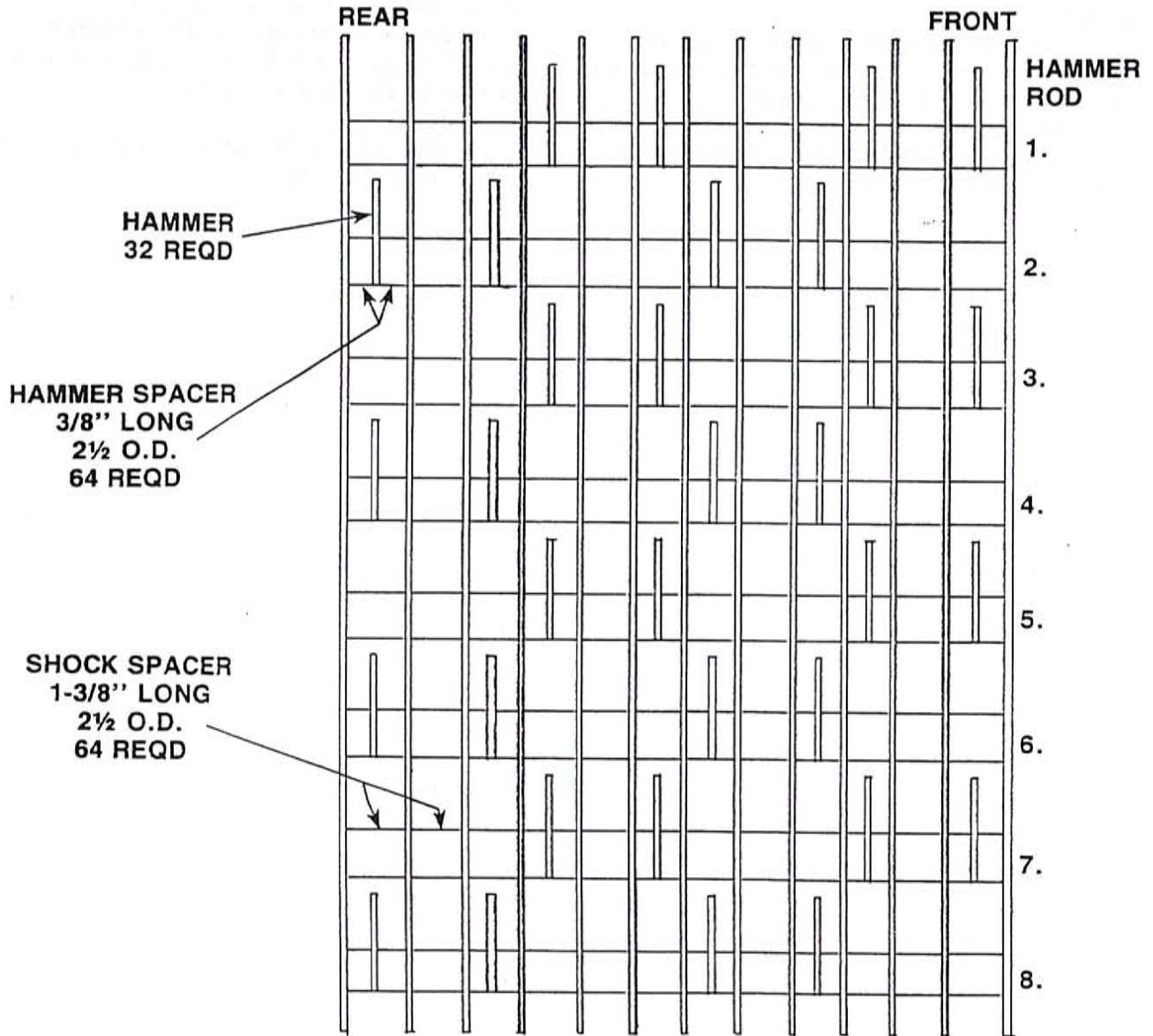



## MAINTENANCE INSTRUCTIONS

### VALVE

Figure E below shows the O-ring replacement sequence. There may be some shims between the compression spring and the Port Plug (Ref. 1.) Do not add or subtract shims from this assembly.

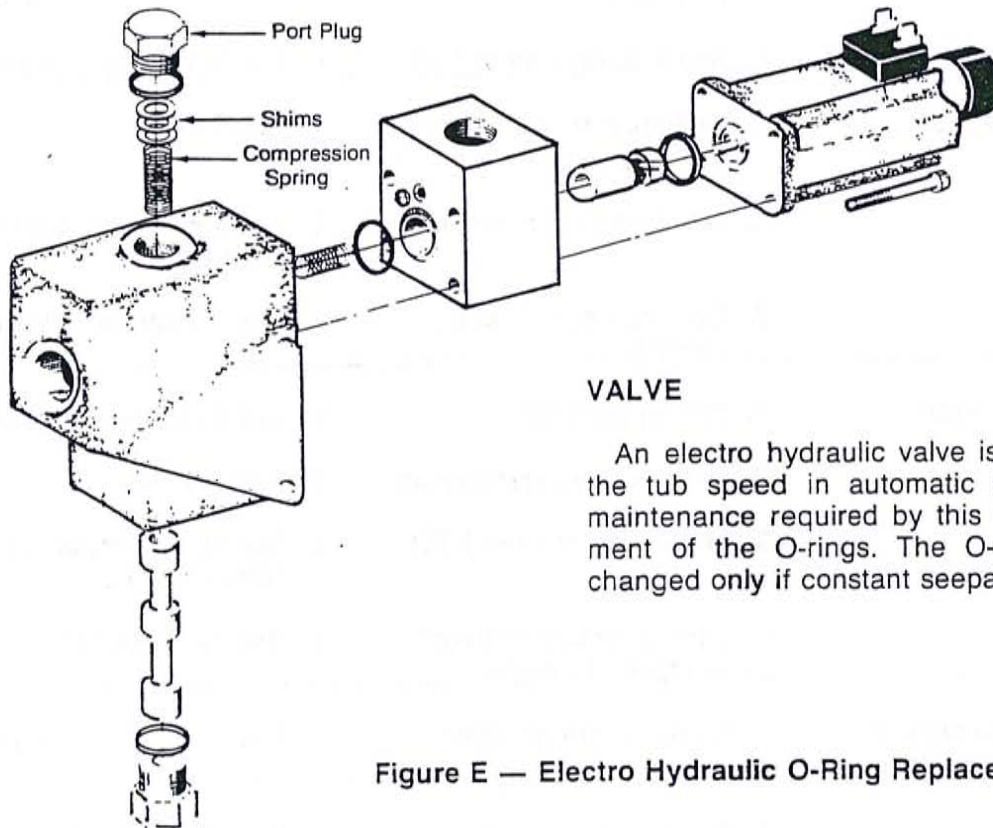

### VALVE

An electro hydraulic valve is used to control the tub speed in automatic mode. The only maintenance required by this valve is replacement of the O-rings. The O-rings should be changed only if constant seepage occurs.

Figure E — Electro Hydraulic O-Ring Replacement Sequence

### HYDRAULIC SYSTEM

Follow Operator's Manual instructions for changing hydraulic oil and filter. Contamina-

tion can cause the electro hydraulic valve to stick. Carefully clean all connections before replacing hoses or working on system.

### ELECTRICAL CONNECTIONS

Periodically check electrical hookups for loose connections and tighten when needed. Check wiring for frayed spots or signs of being rubbed by moving parts.

### FUSE

The Automatic Governor system is protected by a 3-amp AGC fuse located on rear of control box. If no lights come on when basic unit ignition

switch is turned to ON, first try replacing fuse, then proceed to trouble shooting section.

### WARNING LIGHTS

The lights on the control box have replaceable bulbs inside red and amber lenses. To replace the bulb, proceed as follows:

1. Unscrew light from control box.
2. Pull old bulb out of lens.
3. Install new bulb into lens.
4. Screw light back into place.

---

## 16 Trouble Shooting

---

| <b>Problem</b>                                  | <b>Cause</b>                                    | <b>Remedy</b>                        |
|-------------------------------------------------|-------------------------------------------------|--------------------------------------|
| 1. No grinding capacity                         | 1. Screen plugged                               | 1. Clean holes in screen             |
|                                                 | 2. Badly worn screens and/or hammers            | 2. Replace or turn worn parts        |
|                                                 | 3. Material too light or fluffy                 | 3. Mix with heavier material         |
| 2. Tub slows down or turns slowly               | 1. Hydraulic speed control valve closed         | 1. Open valve                        |
|                                                 | 2. Low hydraulic pressure                       | 2. Tighten hydraulic pump drive belt |
|                                                 | 3. Governor not adjusted properly               | 3. See (Governor adjustment)         |
| 3. Excessive vibration                          | 1. Broken hammer                                | 1. See (Hammer replacement)          |
|                                                 | 2. Defective cylinder bearing                   | 2. Replace bearing                   |
|                                                 | 3. Misaligned or worn PTO                       | 3. Replace worn part or complete PTO |
|                                                 | 4. Wire or foreign material wrapped in cylinder | 4. Remove material                   |
| 4. Engine loses excessive RPMs before tub stops | 1. Governor not adjusted properly               | 1. See (Governor adjustment)         |
| 5. Cylinder slugs                               | 1. Slugbuster removed                           | 1. Replace slugbuster                |

---



## TROUBLE SHOOTING INSTRUCTIONS

This guide is intended to help you eliminate trouble with your Electric Governor System. If the problem remains after following these trouble shooting steps, follow the directions under "Manual Override", and see your local dealer as soon as possible.

## WIRING CONNECTIONS

Certain instructions will refer to one or more wiring harness pins for voltage or resistance checks. To find the pins, remove the harness connector from the back of the control box. The drawing below identifies the pin letters called out, the color of wire to each pin and each wire's connection and purpose.

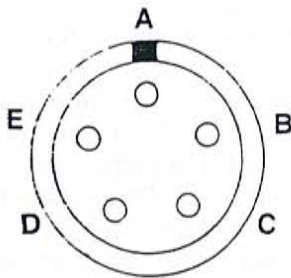

- A — 13 volts DC, ignition
- B — Ground
- C — Digital sensor signal\*
- D — 13 volts DC (+) to valve
- E — 13 volts DC (-) to valve

## TROUBLE AREAS

Identify the trouble area from the following list and follow the checks in the order listed. If the problem remains, go to "Manual Override." The volt-ohm reading chart at the end of this section will help locate the problem area if a volt-ohm meter is being used.

### TUB will not move in Manual or Automatic

- No lights on control box (Model B):  
Trouble checks 7, 8, 9, 10.

\*A digital tach or voltmeter set on AC will pick up the signal from the sensor.

### TUB will move in Manual, but will not move in Automatic.

- Model B  
Trouble checks 2, 3, 5, 13, 14, 15.

### Engine rpm adjustment.

- Engine speed will not remain steady in Automatic (Model B):  
Trouble checks 3, 4, 5, 16, 15, 14.
- Engine speed cannot be reduced by control knob to desired rpm (Model B):  
Trouble checks 4, 5, 15.
- Engine speed cannot be increased by control knob to desired rpm (Model B):  
Trouble checks 3, 15.

### Miscellaneous problems:

- System will not go to Manual mode when ignition key is turned on (Model B):  
Trouble check 17.
- System jumps from Auto to Manual mode (Model B):  
Trouble checks 6, 7, 8.
- Fuse blows repeatedly (Model B):  
Trouble checks 10, 12.

## TROUBLE CHECKS

1. Check the condition of the hydraulic system
2. Make sure alternator/charging system is working.
3. Make sure engine is operating correctly at the proper rpm.
4. Make sure tub speed is fast enough to place load on engine. Try turning engine rpm knob toward minimum setting to increase tub speed, or run in Manual to check engine loading.



---

## 18 Trouble Shooting

---

5. Be certain the engine rpm is at the correct rpm and stays in place.
  6. Check the wire from the battery or ignition switch to be certain 13 VDC is being supplied to the control box. With the engine running or off, pin A to chassis ground should equal 13 VDC. If your machine is wired through the ignition switch, be certain the switch is "ON."
  7. With the engine "OFF", check wire to chassis ground. Pin B to chassis ground should have less than 5 ohms resistance. Higher readings indicate defective wiring.
  8. Check fuse on the back of the control box. If burned out, replace with 3 amp, type AGC fuse. **Note:** Some units were equipped with pop-out type circuit breakers. Wait until cool and reset by pushing in plunger.
  9. Check control box lights (light) as follows: Attach lead to the battery or turn ignition switch "ON"; do not start engine. The manual and rpm lights should come on. Push the toggle switch to auto; the auto, rpm, and valve lights should light. If the valve light does not come on, either the valve or valve wiring is defective.
  10. Check wires from the control box to the valve. Disconnect the battery lead or turn the ignition switch "OFF" and measure the resistance from pin D to pin E on the wire harness. The reading should be 9.6 ohms resistance. Other readings indicate defective wiring or valve. See Trouble Check 12, also for more info.
  11. Disconnect battery leads or turn "OFF" ignition switch and remove the wires from the electronic valve. **NOTE: DO NOT ALLOW THE WIRES TO TOUCH THE BASIC UNIT OR EACH OTHER. THE CONTROL BOX COULD SHORT OUT WHEN THE POWER IS RECONNECTED.** Connect battery leads or turn "ON" the ignition switch, but do not start engine. Place control box switch in MANUAL and check voltage at the ends of the valve wires. Voltage should be 12-13 VDC. Lower readings indicate defective wiring, control box or battery.
  12. Leave the valve wires off the electronic valve and turn "OFF" the ignition to disconnect the battery leads. Check the resistance between terminals on the valve. Resistance should be 9.6 ohms. Other readings indicate a defective valve.
  13. Check wire circuit to the alternator or magnetic sensor. On alternator sensed models, with engine running at maximum no load rpm; pin C to chassis ground should carry about 13 VDC. Lower readings indicate defective wiring, alternator tap, or alternator. On magnetic sensor models, check the output of the sensor at full rpm with a digital voltmeter set on AC-13V. range. If you receive a reading on the voltmeter, the sensor is working. Different designs will yield different readings. If there is no reading, replace wires or sensor.
  14. Check valve wire circuit for voltage fluctuations with the engine running. With the engine running at maximum rpm, the control box switch in AUTOMATIC, and no load in the drum; turn the engine knob clockwise to MAX position. Voltage between the two valve wires should read between 4 and 10 VDC. Slowly reduce the engine rpm. Voltage should drop to 1-2 volts as the engine rpm falls. When the engine rpm is increased, the voltage reading should increase. Other readings indicate the control box is out of adjustment or the wiring or the control box is defective.
  15. Check the control box calibration, see section describing calibration under operating instructions.
  16. Check engine rpm knob. If knob is rotating due to operating vibrations the "O" ring between the control box and the knob is defective or is missing.
  17. The diode is missing or defective within the alternator.  
**NOTE: IF THERE IS AN ELECTRICAL FAILURE WITH YOUR MACHINE YOU MAY STILL GRIND. REMOVE THE RUBBER END CAP FROM THE VALVE AND FOLLOW THE INSTRUCTIONS BELOW. WITH THE MANUAL OVERRIDE IN THE DESIRED DISTANCE THE VALVE IS JUST AS AN ADJUSTABLE FLOW CONTROL.**
-

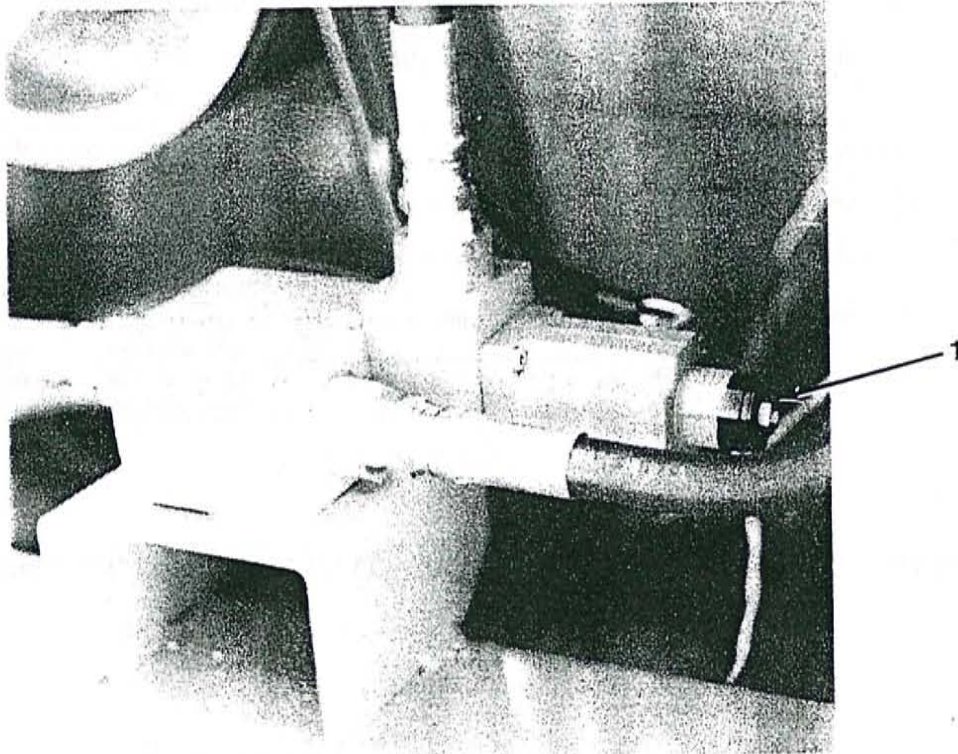

**Figure G - Manual Override Bolt Location**

Contact your local dealer for further repairs or replacement. When problem is corrected, loosen locknut and turn bolt out (counter clockwise) until it stops. Retighten locknut. If bolt comes all the way out, screw back in 3 half turns and tighten locknut.

### MANUAL OVERRIDE

If problems remain, use manual override bolt on electronic governor valve (Ref. 1, Fig. G). Loosen locknut and turn bolt completely in (clockwise). Tighten locknut and operate basic unit as if Governor was not installed.



## 20 Trouble Shooting

### ELECTRONIC GOVERNOR VOLT-OHM READINGS

| WIRE HARNESS CONNECTOR                            | ENGINE                   | IGNITION SWITCH | READING                            | INCORRECT READING INDICATES            | CHECK IF INCORRECT READING   |
|---------------------------------------------------|--------------------------|-----------------|------------------------------------|----------------------------------------|------------------------------|
| Valve terminals system in Manual (Wires attached) | Not running              | ON              | 13 volts DC                        | Defective wiring, control box.         | Wires to valve.              |
| Valve terminals, system in Auto (Wires attached)  | Running 1500 to 2550 rpm | ON              | 1-10 volts DC varies with rpm<br>★ | Defective wiring, control box.         | Wires to valve.              |
| Valve terminals, (Wires removed)                  | Not running              | OFF             | 9.6 ohms                           | Defective valve.                       |                              |
| Pin A to Pin B                                    | Not running              | ON              | 13 volts DC                        | 13 volts not at control box, no ground | Wires to tractor.            |
| Pin A to Ground                                   | Not running              | ON              | 13 volts DC                        | 13 volts power not reaching box        | Wires to tractor.            |
| Pin B to Ground                                   | Not running              | OFF             | Less than 5 ohms                   | Black wire not grounded                | Ground wire.                 |
| Pin D to Pin E                                    | Not running              | OFF             | 9.6 ohms                           | Valve wiring or valve defective        | Wires to valve, valve.       |
| Pin D to Ground                                   | Not running              | OFF             | Infinite ohms                      | Valve wiring or valve defective        | White wire to valve, valve.  |
| Pin E to Ground                                   | Not running              | OFF             | Infinite ohms                      | Valve wiring or valve defective        | Blue or black wire to valve. |

★ Typically 4.0 to 4.5 VDC at full engine rpm with the knob turned fully clockwise.

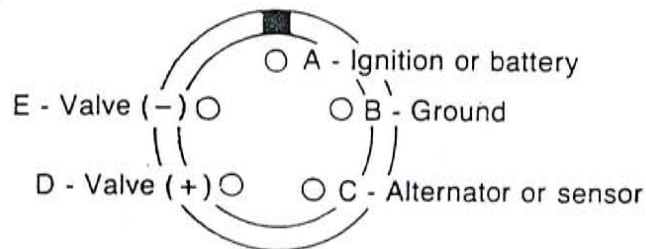



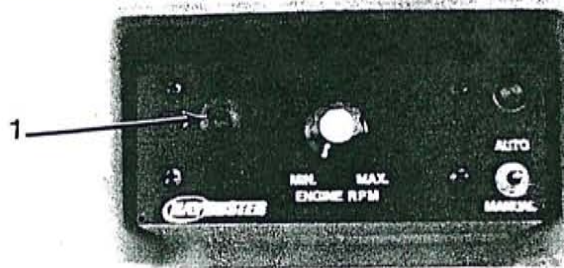

MODEL B

## ELECTRONIC GOVERNOR

**READ THIS FIRST:** Haybuster Manufacturing test runs every grinder before it leaves the factory. The control box was calibrated at this time and should not need any further adjustment. Before attempting to adjust the control box, read the trouble shooting section, pages 15 through 21.

## CONTROL BOX ADJUSTMENT

With engine running at PTO speed (2000 rpm), set control box engine rpm dial in the 12 o'clock position and set toggle switch in auto position.

**Step 1. Model B.** Check indicator light on your control box before doing any adjusting! At this point, the auto light should be lit. If it is not, read the trouble shooting section, pages 15 through 21.

Call your dealer before attempting to recalibrate your control box. Before proceeding to Steps 2 and 3, read this message!

**WARNING:** The control box calibration screw should be adjusted with a small screw driver and a light touch. Due to its small size, this screw can be damaged if extreme caution is not used. Any damage to this screw IS NOT COVERED UNDER WARRANTY.

**Step 2.** IF TUB IS TURNING remove plug, slowly turn screw No. 1, counter clockwise until tub creeps slowly.

The screw will turn both directions and is ratcheted at each end. There are 20 turns from one end to the other and it is possible for you to adjust the screw so that no tub movement is possible.

**Step 3.** IF TUB IS NOT TURNING, slowly turn screw No. 1, clockwise until tub creeps slowly.

The screw will turn both directions and is ratcheted at each end. There are 20 turns from one end to the other and it is possible for you to adjust the screw so that no tub movement is possible. If you have been turning clockwise, reverse your direction and slowly attempt to find the range for your machine and rpm.

Replace plug when adjustment is completed. If the tub does not moved in the automatic mode after you have attempted to calibrate the control box, refer to the trouble shooting section for further action.

## OPERATION

Turning engine rpm control counter clockwise will increase load on tractor by keeping tub rotation engaged at lower engine rpm.

Turning engine rpm control clockwise will decrease load on tractor by disengaging tub rotation at a higher rpm.

With Control Box switched to manual, tub will continue to rotate regardless of tractor rpm.

## 12 VOLT SYSTEM NEGATIVE GROUND

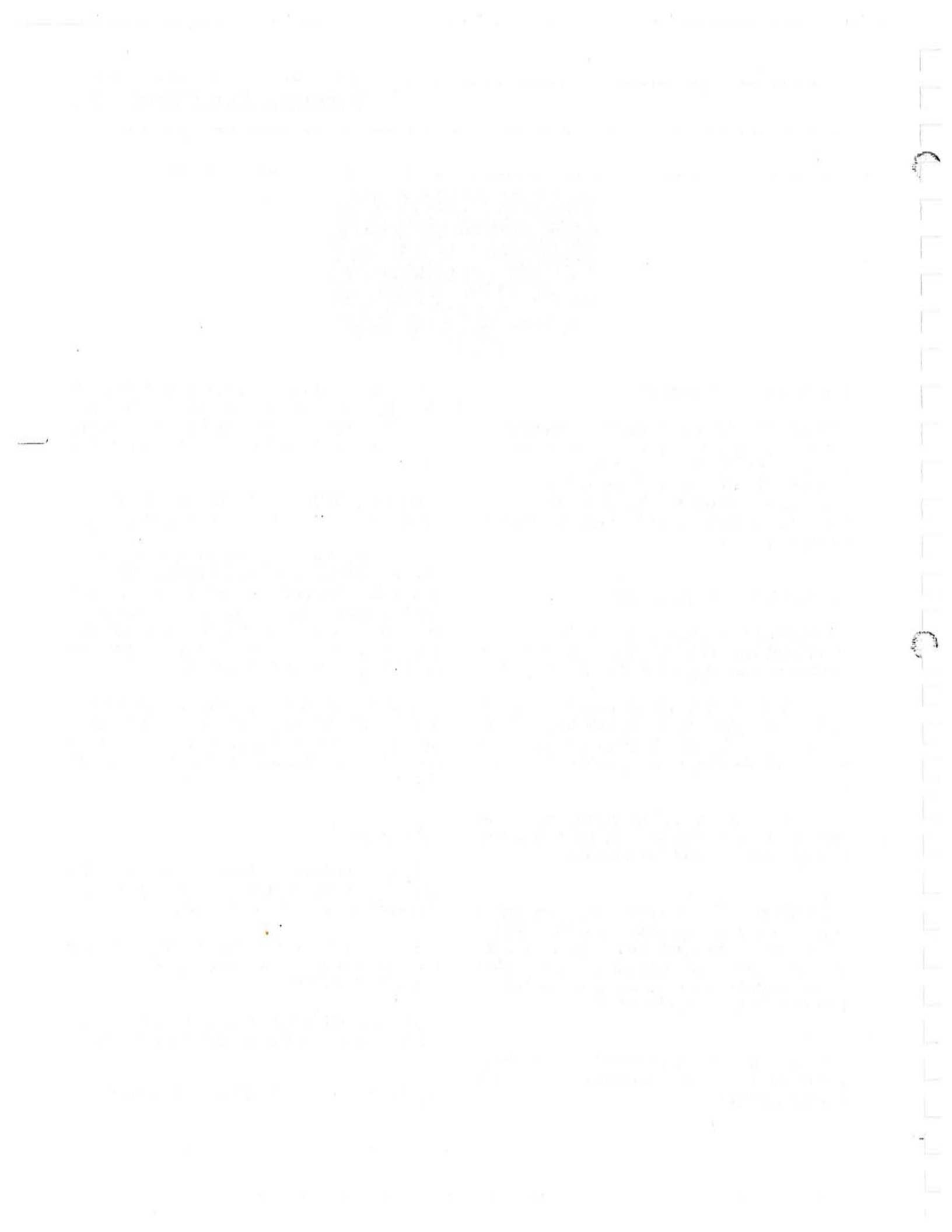



**HAYBUSTER**

**IG-7**

**PARTS BOOK**

## 22 Main Frame (Front)

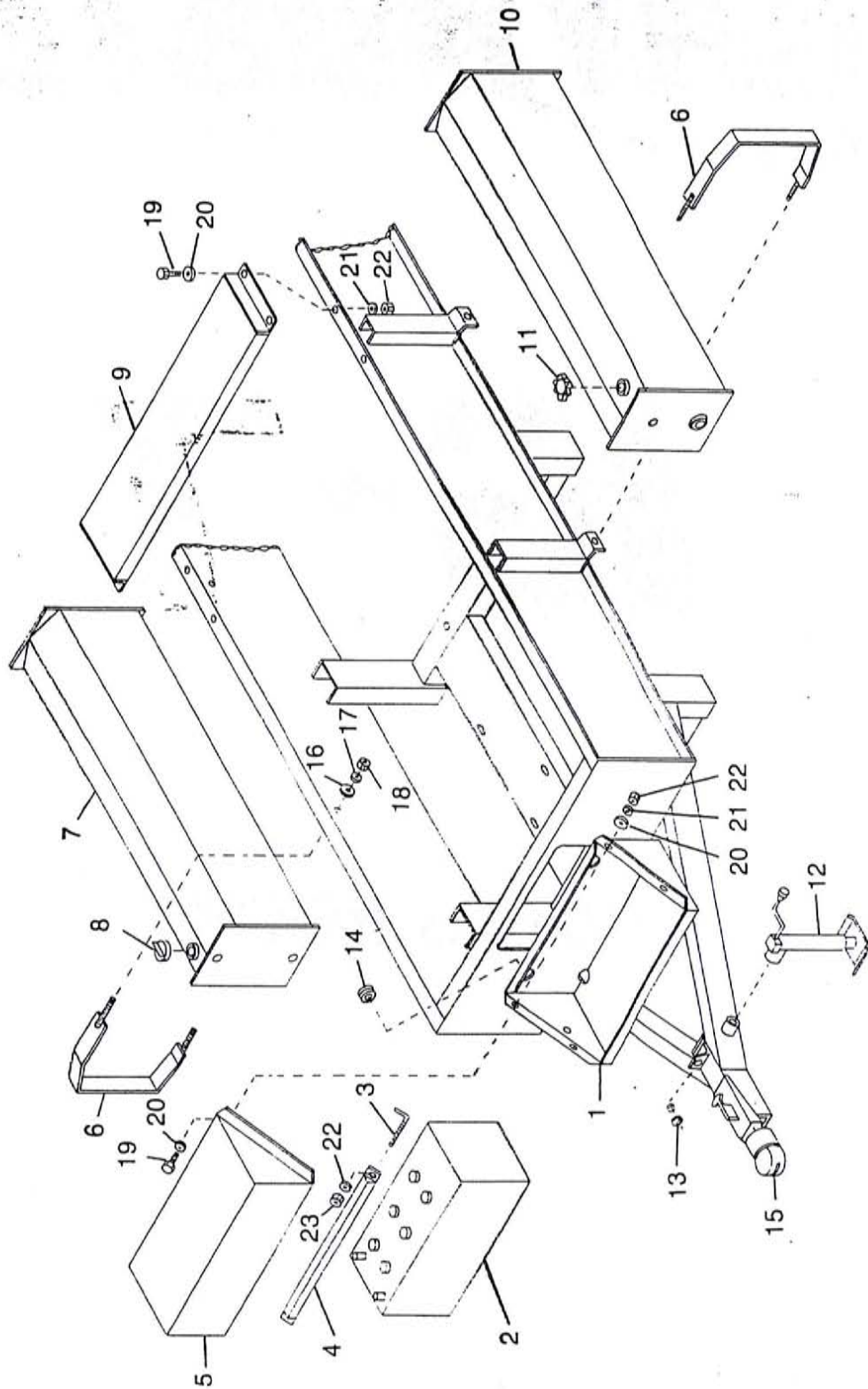





# 24 Tub Deck Drive

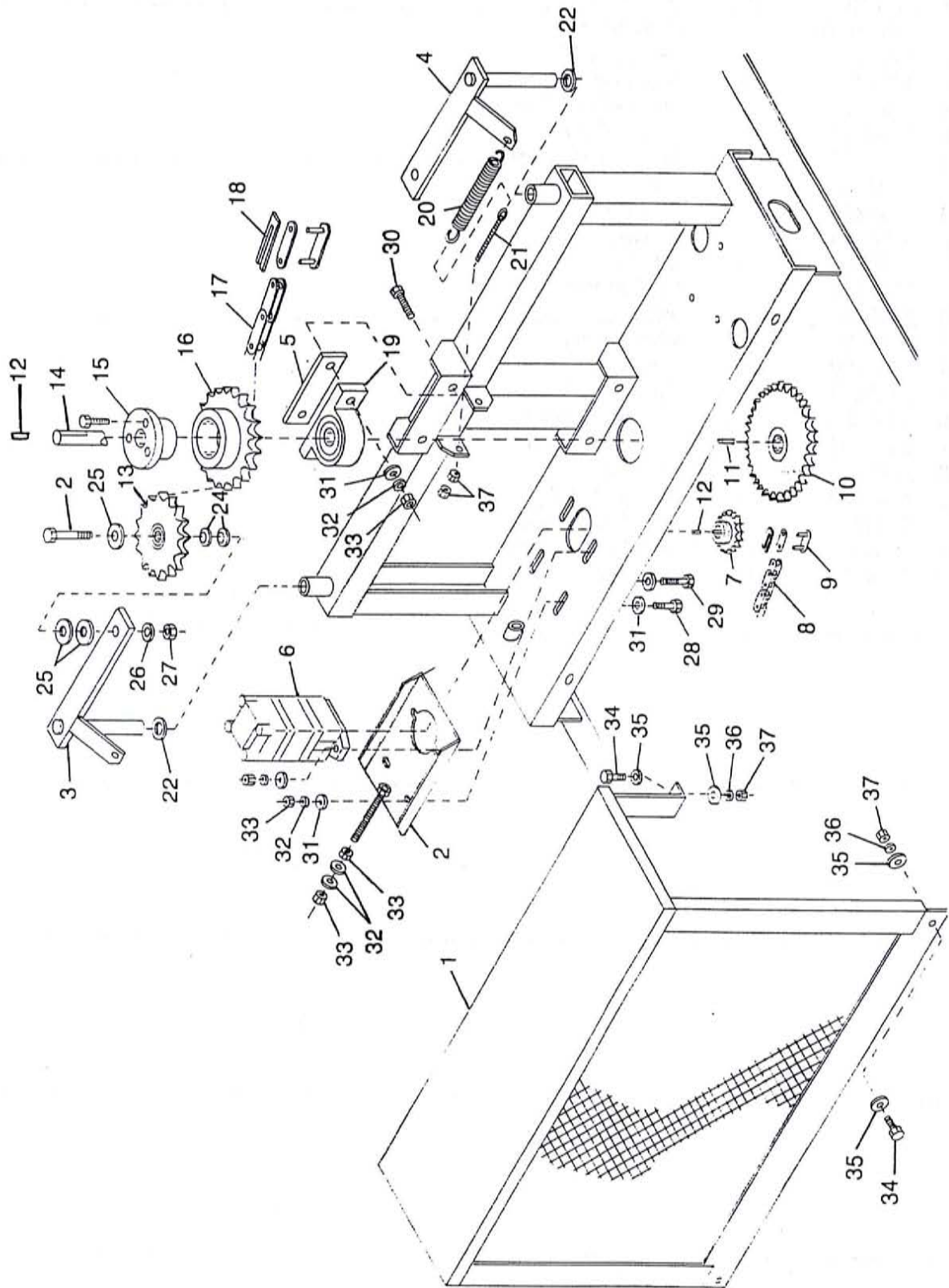



## Tub Deck Drive 25

| Item | Part No. | Qty. | Description                    |
|------|----------|------|--------------------------------|
| 1    | 4700221  | 1    | Tub Drive Shield               |
| 2    | 4700018  | 1    | Orbit Motor Tightening Bracket |
| 3    | 4700222  | 1    | Swing Idler Arm, Right Hand    |
| 4    | 4700223  | 1    | Swing Idler Arm, Left Hand     |
| 5    | 4700224  | 6    | Bearing Shim                   |
| 6    | 3900010  | 1    | Orbit Motor                    |
| 7    | 1000127  | 1    | 60-15-1¼" Sprocket             |
| 8    | 1100045  | 1    | 60 Chain 47 Links              |
| 9    | 1100062  | 1    | 60 Connector Link              |
| 10   | 1000009  | 1    | 60-36 Sprocket 1¼"             |
| 11   | 6200019  | 1    | ¼" x 2½" Square Key            |
| 12   | 6200004  | 2    | 5/16" x 1½" Square Key         |
| 13   | 1000123  | 2    | 80-18 Idler Sprocket           |
| 14   | 4700225  | 1    | Tub Drive Shaft 1¼" x 23"      |
| 15   | 1500015  | 1    | Hub Q1-1¼"                     |
| 16   | 1000124  | 1    | 80-21 Sprocket                 |
| 17   | 1100155  | 1    | 2080 Chain 101 Links           |
| 18   | 1100070  | 1    | 2080 Connector Link            |
| 19   | 1800002  | 2    | Bearing 1¼" Pillow Block       |
| 20   | 1600009  | 2    | Spring                         |
| 21   | 4700226  | 2    | Spring Tension Bolt 3/8" x 8"  |
| 22   | 5000040  | 2    | 1" Narrow Rim Maching Bushing  |
| 23   | 4800017  | 2    | ¾" x 3" Bolt                   |
| 24   | 5000037  | 4    | Cone Washer                    |
| 25   | 5000005  | 6    | ¾" Flat Washer                 |
| 26   | 5000012  | 2    | ¾" Lock Washer                 |
| 27   | 4900004  | 2    | ¾" Nut                         |
| 28   | 4800082  | 2    | ½" x 1½" Bolt                  |
| 29   | 4800114  | 2    | ½" x 2" Bolt                   |
| 30   | 4800070  | 4    | ½" x 2½" Bolt                  |
| 31   | 5000004  | 14   | ½" Flat Washer                 |
| 32   | 5000006  | 8    | ½" Lock Washer                 |
| 33   | 4900001  | 10   | ½" Nut                         |
| 34   | 4800003  | 4    | 3/8" x 1" Bolt                 |
| 35   | 5000001  | 8    | 3/8" Flat Washer               |
| 36   | 5000019  | 4    | 3/8" Lock Washer               |
| 37   | 4900002  | 8    | 3/8" Nut                       |
| 38   | 1100063  | 1    | 60 Offset Link                 |

# 26 Main Frame (Rear)

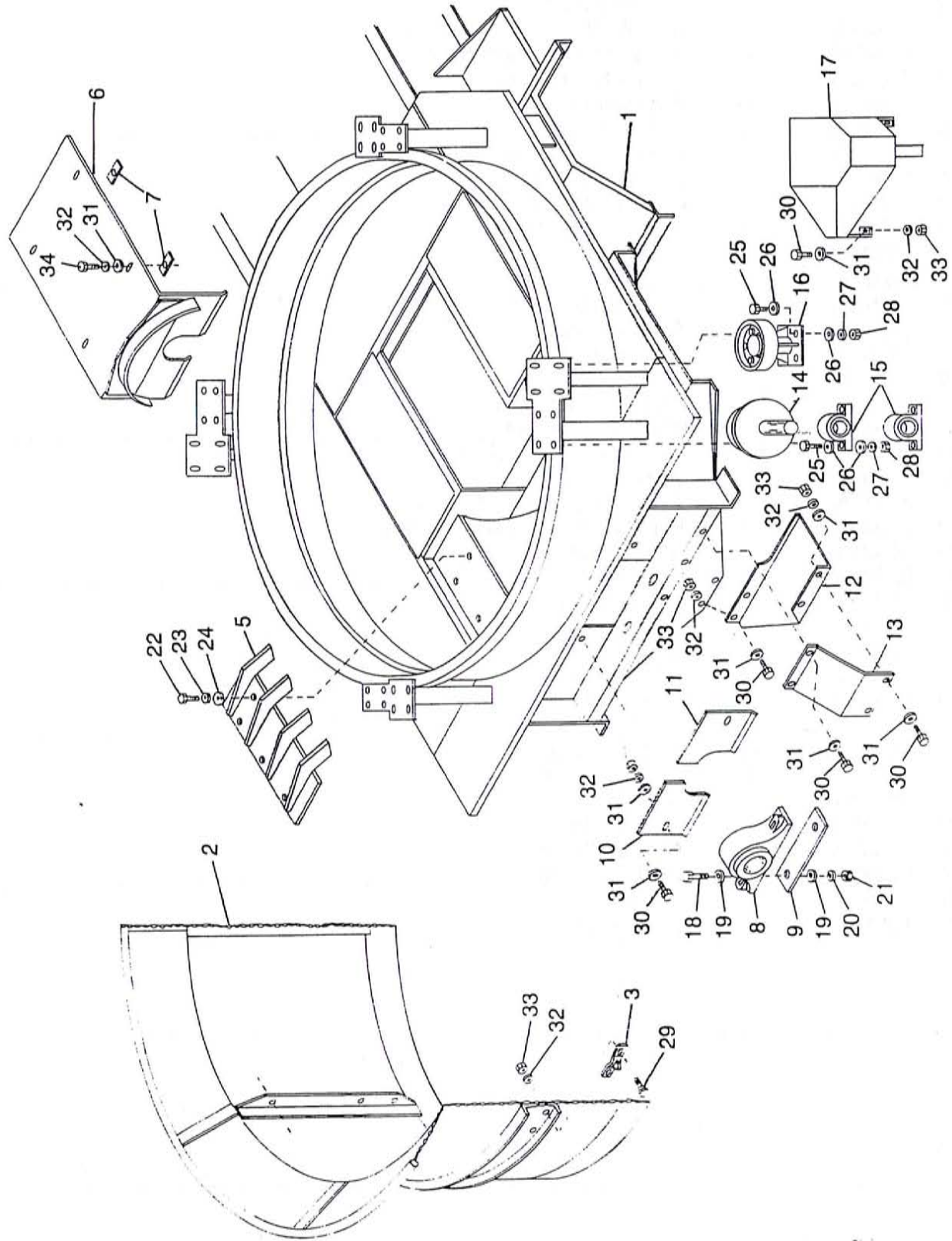





# 28 Cylinder

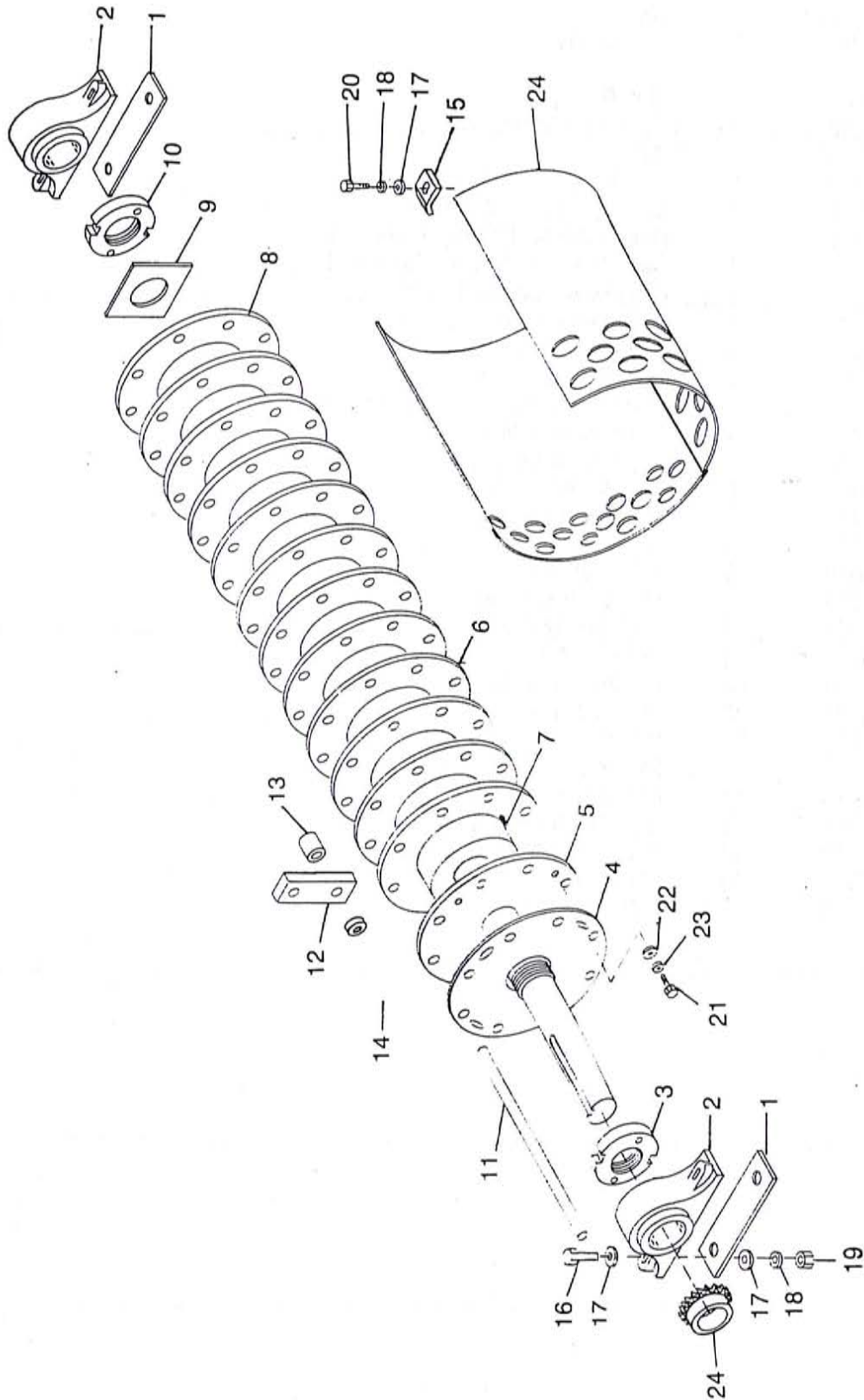









# Conveyor 31

| Item | Part No. | Qty. | Description                  |
|------|----------|------|------------------------------|
| 1    | 4700272  | 1    | Conveyor Lower Frame         |
| 2    | 4700273  | 1    | Conveyor Upper Frame         |
| 3    | 4700274  | 1    | Conveyor Belt                |
| 4    | 4700275  | 2    | Conveyor Belt Mounting Strip |
| 5    | 4700276  | 1    | Conveyor Cover               |
| 6    | 4700242  | 1    | Bearing Bracket L.H.         |
| 7    | 4700243  | 1    | Bearing Bracket R.H.         |
| 8    | 4700244  | 2    | Tightening Bolt              |
| 9    | 4700277  | 1    | Idler Roller                 |
| 10   | 17000459 | 1    | Belt 18" x 187"              |
| 11   | 1700036  | 1    | Lacing Pin 18"               |
| 12   | 4700246  | 2    | Fold Latch Pin               |
| 13   | 4800256  | 2    | Rolled Pin 3/16" x 1 1/2"    |
| 14   | 6100031  | 2    | Spring                       |
| 15   | 4700247  | 2    | Hinge Bushing                |
| 16   | 4700248  | 2    | Bearing Adjusting Strap      |
| 17   | 4700278  | 1    | Drive Roller                 |
| 18   | 4700250  | 1    | Orbit Motor Mounting Bracket |
| 19   | 4700251  | 1    | Orbit Motor Shim             |
| 20   | 1800007  | 4    | Bearing 1-1/8" Pillow Block  |
| 21   | 3900003  | 1    | Orbit Motor 207              |
| 22   | 6200011  | 1    | 1/4" x 1" Woodruff Key       |
| 23   | 1100026  | 1    | Coupler Chain                |
| 24   | 1100099  | 1    | Connector Link               |
| 25   | 1000029  | 1    | Coupler Sprocket 1" Bore     |
| 26   | 1000125  | 1    | Coupler Sprocket 1-1/8" Bore |
| 27   | 5000002  | 4    | 5/8" Flat Washer             |
| 28   | 4900005  | 4    | 5/8" Hex Nut                 |
| 29   | 4800082  | 2    | 1/2" x 1 1/2" Bolt           |
| 30   | 4800018  | 6    | 1/2" x 1 1/4" Bolt           |
| 31   | 5000004  | 16   | 1/2" Flat Washers            |
| 32   | 5000006  | 6    | 1/2" Lock Washers            |
| 33   | 4900001  | 10   | 1/2" Nut                     |
| 34   | 4900014  | 2    | 1/2" Lock Nut                |
| 35   | 4800146  | 4    | 3/8" x 2" Bolt               |
| 36   | 4800034  | 4    | 3/8" x 1 1/2" Bolt           |
| 37   | 4800003  | 12   | 3/8" x 1" Bolt               |
| 38   | 5000001  | 32   | 3/8" Flat Washer             |
| 39   | 5000019  | 20   | 3/8" Lock Washer             |
| 40   | 4900002  | 20   | 3/8" Hex Nut                 |

# 32 Hydraulics

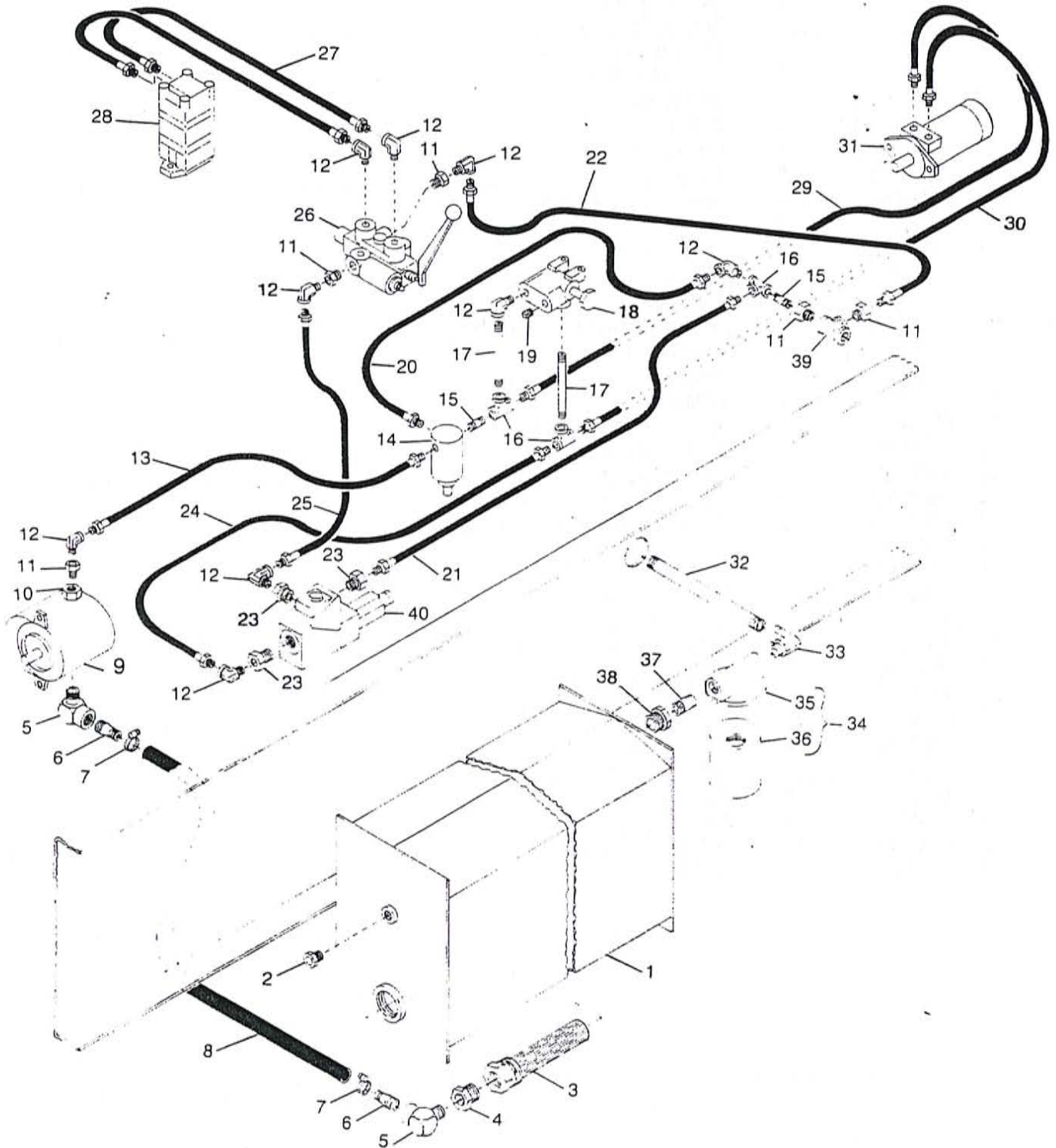



| Item | Part No. | Qty. | Description                                  |
|------|----------|------|----------------------------------------------|
| 1    | 4700220  | 1    | Oil Tank                                     |
| 2    | 3800137  | 1    | 3/4" Site Glass                              |
| 3    | 4400007  | 1    | Strainer S25                                 |
| 4    | 3800046  | 1    | 1 1/4" to 1" Bushing                         |
| 5    | 3800021  | 2    | 1" 90° Street Elbow                          |
| 6    | 3800056  | 2    | King Nipple 1"                               |
| 7    | 3800024  | 2    | Hose Clamp                                   |
| 8    | 3700178  | 1    | 1" x 22" Suction Hose                        |
| 9    | 4200003  | 1    | Pump                                         |
| 10   | 3800131  | 1    | 1" to 3/4" Bushing                           |
| 11   | 3800010  | 5    | 3/4" to 1/2" Bushing                         |
| 12   | 3800008  | 9    | 1/2" 90° Street Elbow                        |
| 13   | 3700059  | 1    | 1/2" to 46" Hose                             |
| 14   | 4000017  | 1    | Relief Valve                                 |
| 15   | 3800005  | 2    | 1/2" Close Nipple                            |
| 16   | 3800009  | 3    | 1/2" Tee                                     |
| 17   | 3800138  | 2    | 1/2" x 6" Nipple                             |
| 18   | 4000020  | 1    | Selector Valve                               |
| 19   | 3800139  | 1    | 1/2" Plug                                    |
| 20   | 3700017  | 1    | 1/2" x 24" Hose                              |
| 21   | 3700110  | 1    | 1/2" x 20" Hose                              |
| 22   | 3700064  | 1    | 1/2" x 26" Hose                              |
| 23   | 3800047  | 3    | 1" Straight to 1/2" Pipe Bushing O-Ring Boss |
| 24   | 3700017  | 1    | 1/2" x 24" Hose                              |
| 25   | 3700017  | 1    | 1/2" x 24" Hose                              |
| 26   | 4000035  | 1    | Control Valve                                |
| 27   | 3700028  | 2    | 1/2" x 48" Hose                              |
| 28   | 3900010  | 1    | Orbit Motor                                  |
| 29   | 3700002  | 1    | 1/2" x 110" Hose                             |
| 30   | 3700132  | 1    | 1/2" x 115" Hose                             |
| 31   | 3900003  | 1    | Orbit Motor                                  |
| 32   | 3800140  | 1    | 3/4" x 10" Nipple                            |
| 33   | 3800129  | 1    | 3/4" 90° Street Elbow                        |
| 34   | 4400006  |      | Filter Complete F4E                          |
| 35   | 4400004  | 1    | Filter Base F4E                              |
| 36   | 4400005  | 1    | Filter Element F4E                           |
| 37   | 3800141  | 1    | 3/4" x 2" Nipple                             |
| 38   | 3800131  | 1    | 1" to 3/4" Bushing                           |
| 39   | 3800017  | 1    | 3/4" Tee                                     |
| 40   | 4300008  | 1    | Control Block                                |
| 41   | 3200018  | 1    | Control Block (Seal Kit)                     |
| 42   | 4300010  | 1    | Control Block (Solenoid)                     |





**Prefilter (Cummins Engine Only) 39**

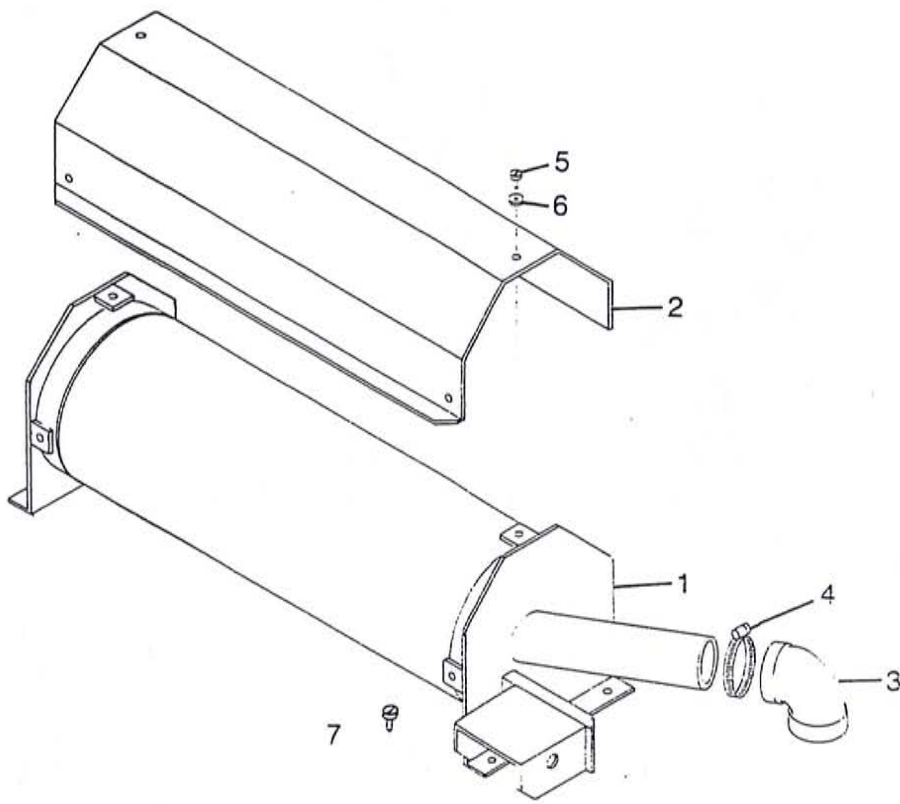

| Item | Part No. | Qty. | Description                   |
|------|----------|------|-------------------------------|
| 1    | 4700255  | 1    | Prefilter (Cummins)           |
| 2    | 4700256  | 1    | Prefilter Cover (Cummins)     |
| 3    | 7500296  | 1    | Elbow 3"                      |
| 4    | 7500297  | 2    | Hose Clamp 4"                 |
| 5    | 4800154  | 6    | 1/4" x 1/2" Screw             |
| 6    | 5000024  | 6    | 1/4" Lock Washer              |
| 7    | 4800258  | 4    | 1/4" x 1" Self Drilling Screw |

# 40 Electronic Governor

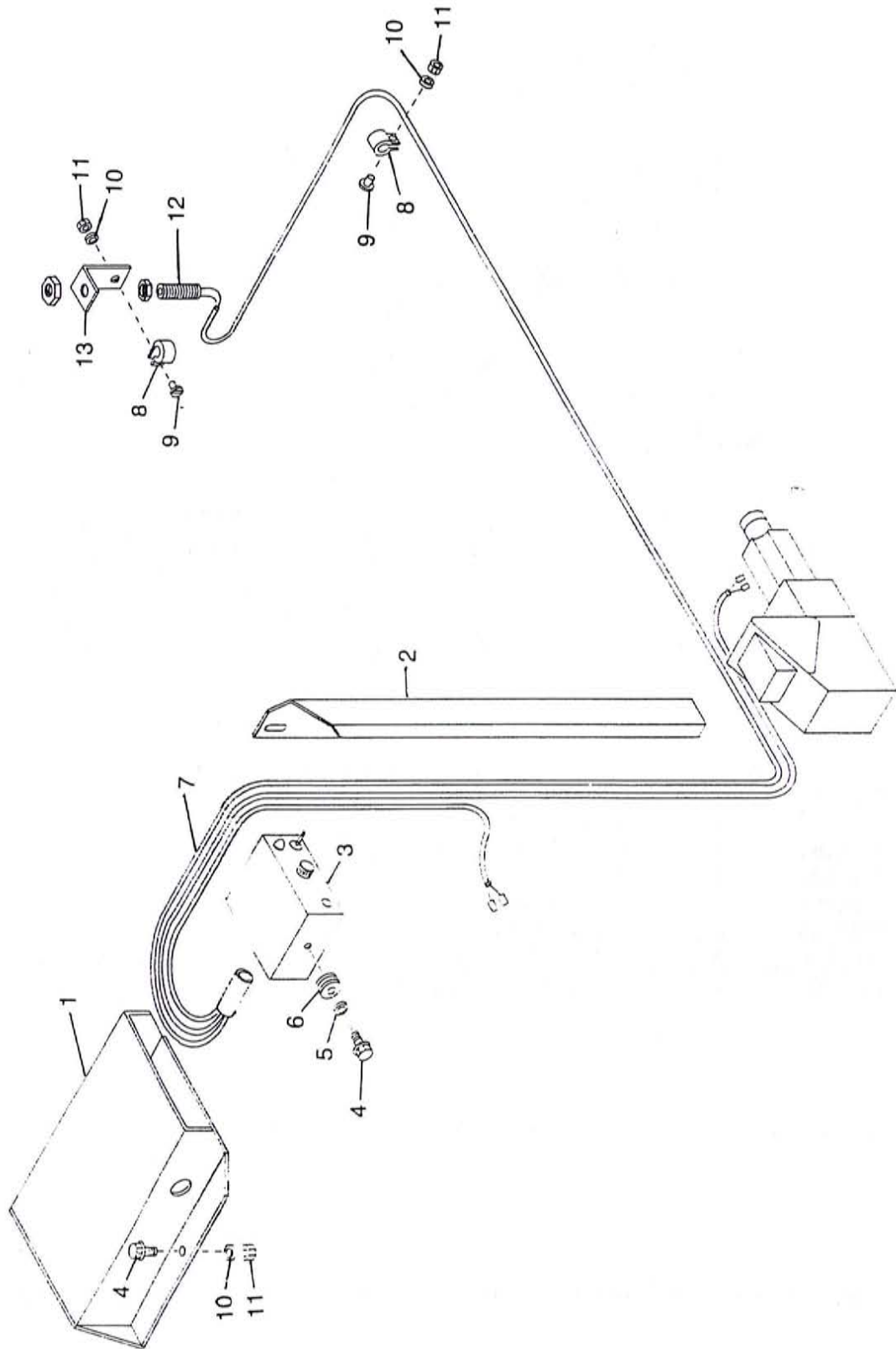





# 42 Lights - Wiring Schematic

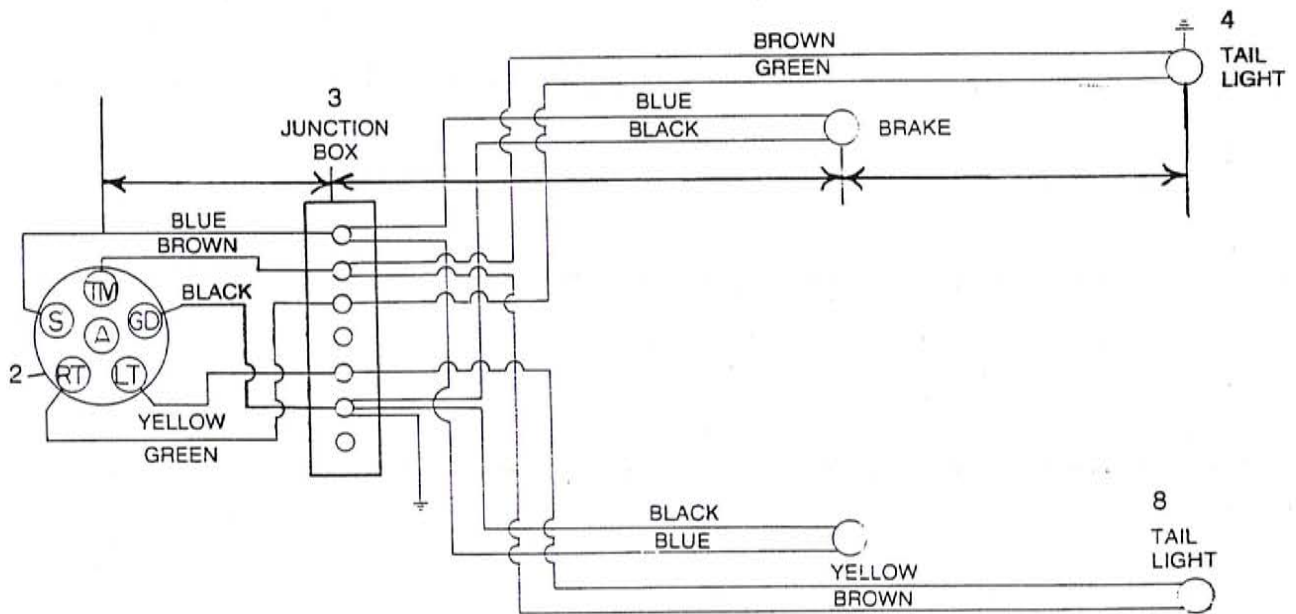





# 44 Pressure Roller

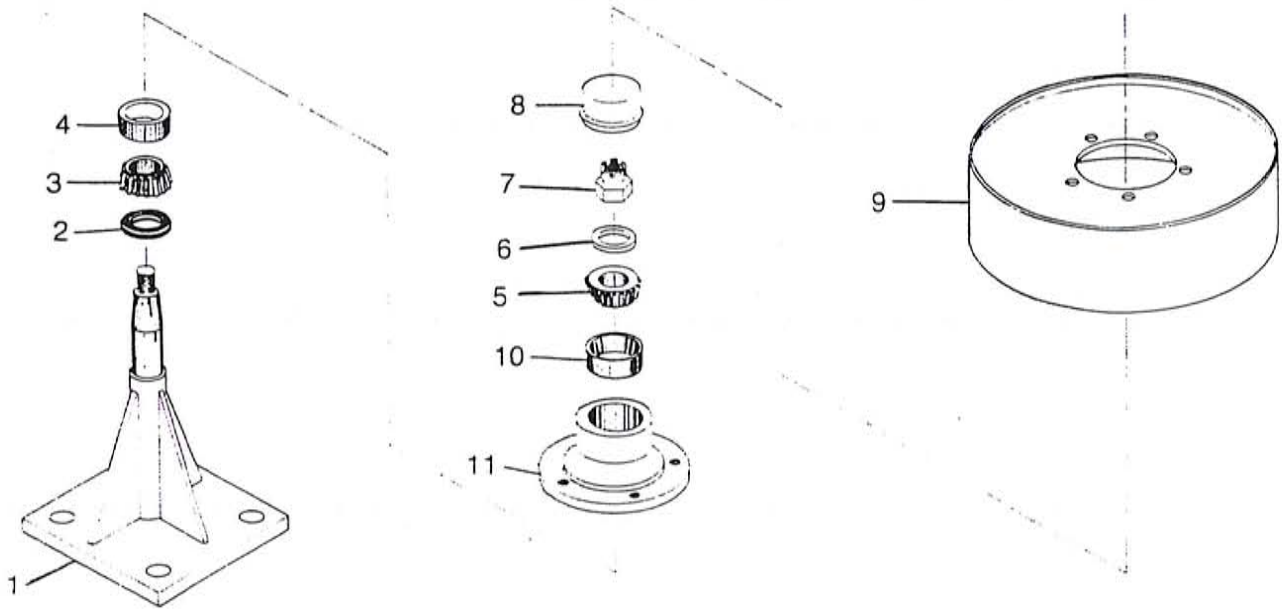

| Item | Part No. | Qty. | Description                         |
|------|----------|------|-------------------------------------|
| 1    | 4700261  | 1    | Pressure Roller Stand (11" Spindle) |
| 2    | 2900055  | 1    | Seal                                |
| 3    | 2900018  | 1    | Inner Cone                          |
| 4    | 2900004  | 1    | Inner Cup                           |
| 5    | 2900061  | 1    | Outer Cone                          |
| 6    | 5000057  | 1    | Washer                              |
| 7    | 4900056  | 1    | Nut                                 |
| 8    | 2900064  | 1    | Dust Cap                            |
| 9    | 4700115  | 1    | Pressure Drum                       |
| 10   | 2900056  | 1    | Outer Cup                           |
| 11   | 2900057  | 1    | Hub                                 |
| 12   | 3000025  | 1    | Pressure Roller Spindle             |
| 13   | 4700116  | 1    | Pressure Roller Complete            |

# Hydraulic Valve 45

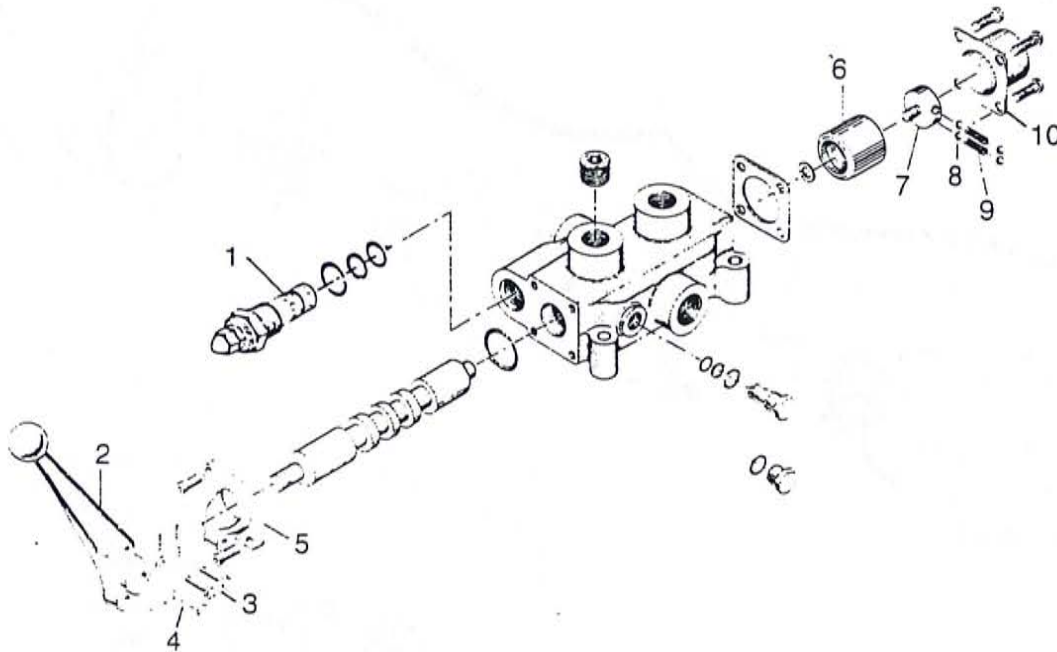

| Item | Part No. | Qty. | Description             |
|------|----------|------|-------------------------|
| 1    | 4000017  | 1    | Adj. Relief Valve       |
| 2    | 4000001  | 1    | Valve Handle            |
| 3    | 4000002  | 1    | Connector Links Handle  |
| 4    | 4000003  | 1    | Pin Handle w/Key        |
| 5    | 4000004  | 1    | Handle Bracket          |
| 6    | 4000025  | 1    | Detent Sleeve           |
| 7    | 4000026  | 1    | Detent Retainer (Screw) |
| 8    | 4000027  | 2    | Detent Spring           |
| 9    | 4000028  | 4    | Ball (1/4" Steel)       |
| 10   | 4000029  | 1    | End Cap                 |
| 11   | 3200013  | 1    | Seal Kit (Not Shown)    |
|      | 4000035  |      | Valve Complete          |

---

## 46 Tub Drive Motor

---

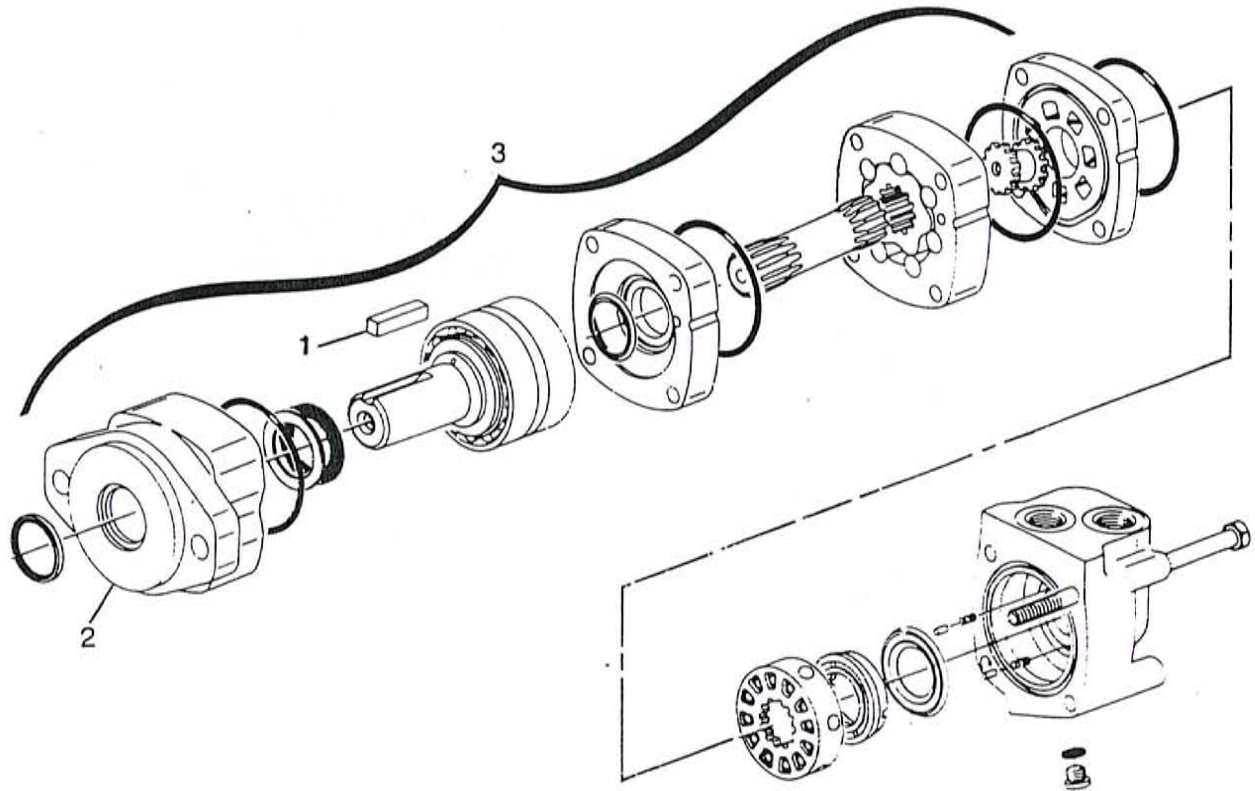

---

| Item | Part No. | Qty. | Description                |
|------|----------|------|----------------------------|
| 1    | 6200004  | 1    | 5/16" x 1 1/2" Key         |
| 2    | 3200005  | 1    | Seal Kit                   |
| 3    | 3900005  | 1    | Complete H2000 Orbit Motor |

---

---

---

---

---



# Orbit Motor 47

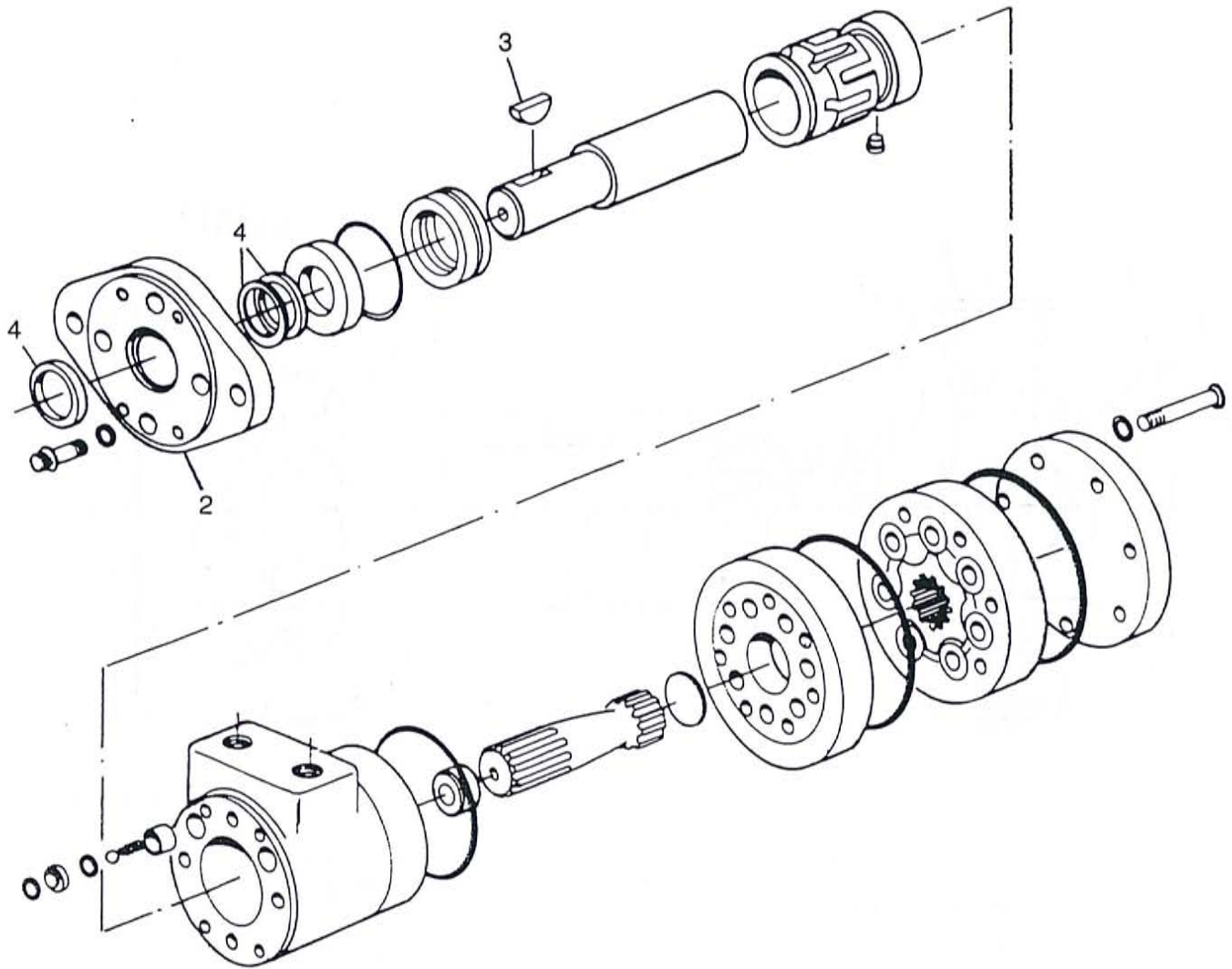

| Item | Part No. | Qty. | Description               |
|------|----------|------|---------------------------|
| 2    | 3900002  | 1    | Mounting Flange           |
| 3    | 6200011  | 1    | Key, Woodruff             |
| 4    | 3200002  | 1    | Seal Kit, Orbit           |
| 5    | 3900003  | 1    | Orbit Motor Complete, 207 |

---

# 48 Power Shaft

---

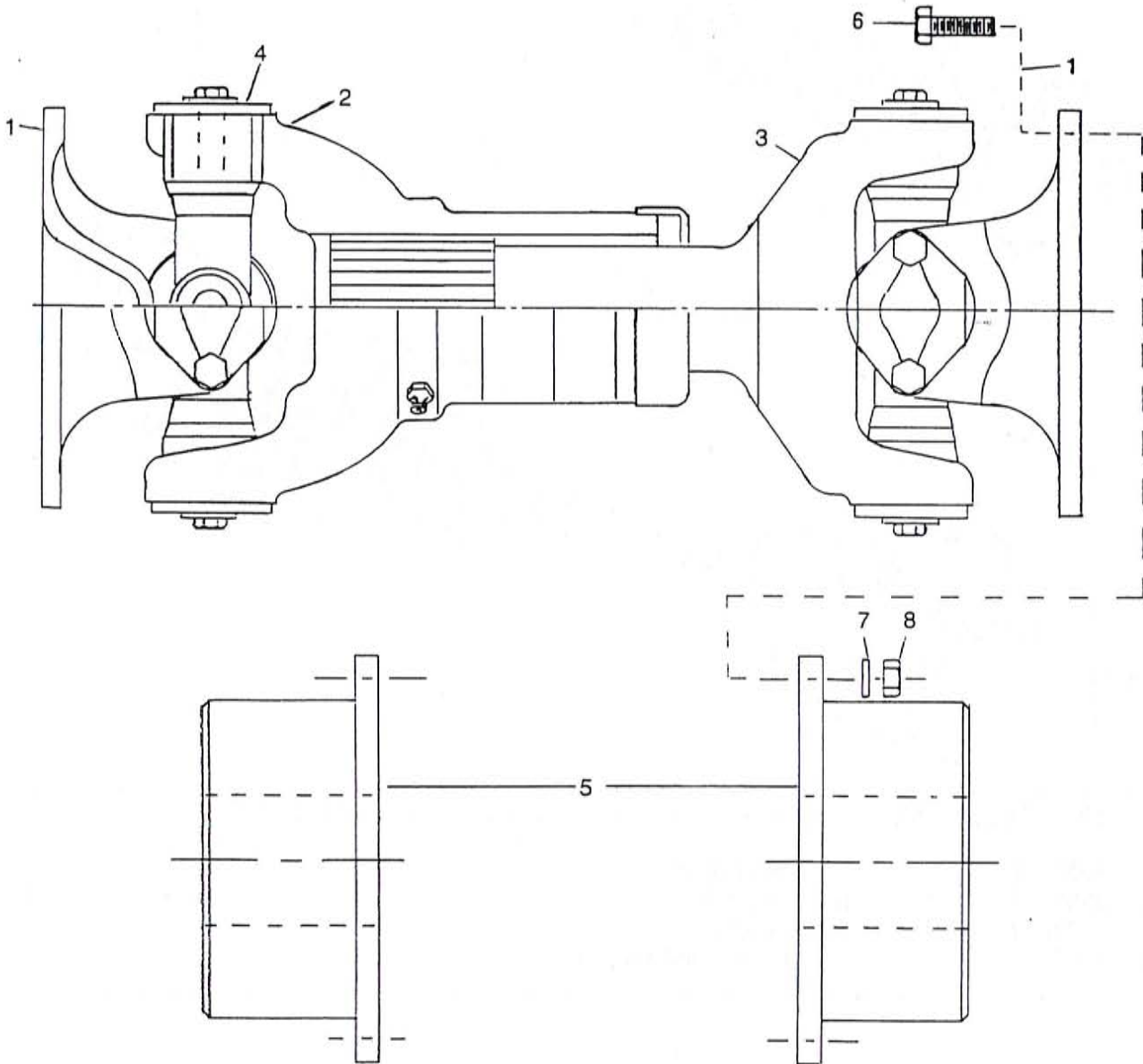





# 50 Decals

12

**IMPORTANT**

DO NOT ENGAGE CLUTCH AT HIGH ENGINE RPM. BEFORE STARTING ENGINE, CYLINDER BOX SHOULD BE CLEARED OF ALL MATERIAL. SET ENGINE AT APPROXIMATELY 1000 RPM. PULL FIRMLY ON LEVER WHEN ENGAGING CLUTCH TO PREVENT EXCESSIVE SLIPPAGE. CHECK PERIODICALLY FOR PROPER ADJUSTMENT ACCORDING TO SPEC. PLATE ON CLUTCH HOUSING. DAMAGE DUE TO EXCESSIVE SLIPPING WILL NOT BE COVERED BY WARRANTY.

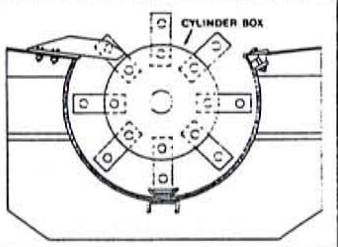

CYLINDER BOX

**1**  **WARNING**

**KEEP OFF MACHINE WHILE IN OPERATION**

6500115

9

**9**  **DANGER**

OBJECTS THROWN BY MACHINE. DO NOT OPERATE WITHOUT WEARING SAFETY GLASSES AND A HARD HAT. KEEP UNAUTHORIZED PERSONNEL OUT OF THE GRINDING AREA!



6500118

**14**  **OIL LEVEL**

6500052

**10** **DIESEL FUEL**

7

**7**  **WARNING** FOR YOUR PROTECTION AND PROTECTION OF OTHERS, PRACTICE THE FOLLOWING SAFETY RULES.

1. BEFORE OPERATING THIS MACHINE, READ THE OPERATOR'S MANUALS SUPPLIED WITH THIS MACHINE AND YOUR TRACTOR.
2. CHECK OPERATOR'S MANUALS TO BE SURE YOUR TRACTOR MEETS THE MINIMUM REQUIREMENTS FOR THIS MACHINE.
3. READ ALL DECALS PLACED ON THIS MACHINE FOR YOUR SAFETY AND CONVENIENCE.
4. NEVER ALLOW RIDERS ON THIS IMPLEMENT OR THE TRACTOR.
5. KEEP OTHERS AWAY FROM THIS MACHINE WHILE IN OPERATION.
6. KEEP ALL SHIELDS IN PLACE WHILE MACHINE IS OPERATING.
7. KEEP HANDS, FEET, LOOSE CLOTHING, ETC., AWAY FROM POWER DRIVEN PARTS.
8. ALWAYS SHUT OFF MACHINE AND ENGINE BEFORE SERVICING, UNCLOGGING, INSPECTING, OR WORKING NEAR THIS MACHINE FOR ANY REASON. ALWAYS PLACE TRANSMISSION IN PARK OR SET PARK BRAKE AND WAIT FOR ALL MOVEMENT TO STOP BEFORE APPROACHING THIS MACHINE.

**5** **KEEP WHEEL BOLTS TIGHT**

800042

6

**6**  **WARNING**

FOR YOUR PROTECTION KEEP ALL SHIELDS IN PLACE AND SECURED WHILE MACHINE IS OPERATING. MOVING PARTS WITHIN CAN CAUSE SEVERE PERSONAL INJURY.

6500049

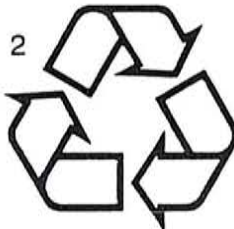

**RECYCLE**

**11** **HYDRAULIC OIL**

**13** **IG-7**

4

**4**  **DANGER**

ROTATING PARTS WITHIN CAN KILL OR DISMEMBER. WAIT FOR ALL MOVEMENT TO STOP BEFORE SERVICING, UNCLOGGING OR INSPECTING MACHINE.

6500082

8

**8**  **ROTATION**

**3** **INDUSTRIAL GRINDER**



---

## 52 Options — Paper Grate

---

---

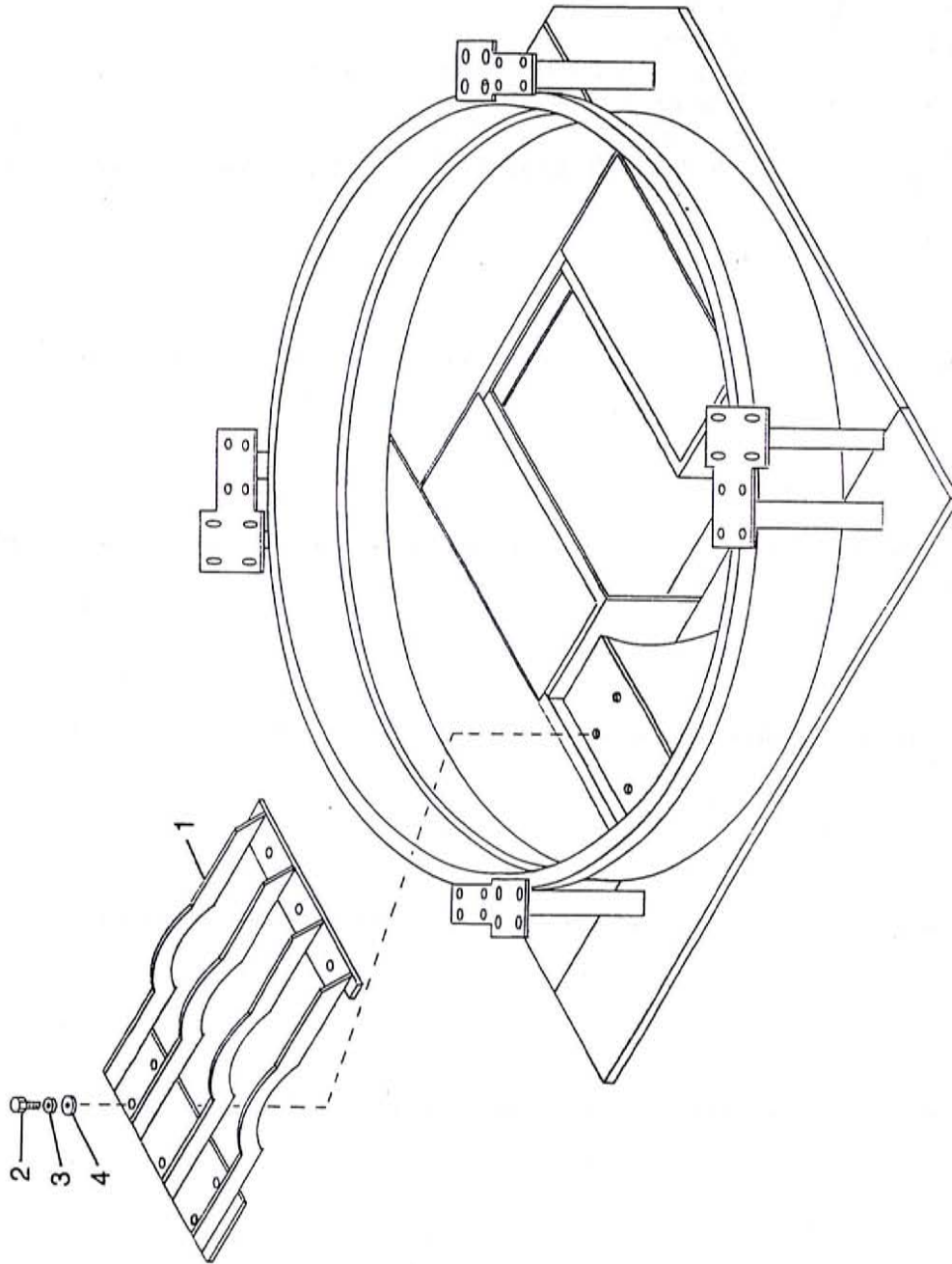





# 54 Tub Agitator

